

Design Guidelines

General requirements

12-05-2026



**Co-funded by
the European Union**

*The sole responsibility of this publication lies with the author.
The European Union is not responsible for any use that may be made of the information contained therein.*

Table of Contents

1.	Abbreviations	6
2.	Standards and specifications	11
2.1.	Specifications applicable for the Design Guidelines	11
2.2.	Specific standards related to General requirements	12
3.	Design standard classification	13
4.	Part A: General operational requirements	15
4A.1.	Line operational principles	15
4A.2.	Speed definitions	15
4A.3.	Passenger trains	16
4A.3.	Freight trains	16
4.	Part B: General infrastructure requirements	18
4B.1	Gauge	18
4B.2.	Structure gauges	21
4B.2.1.	Pantograph	22
4B.2.2.	Mixed traffic sections	24
4B.2.3.	Passengers only and light freight traffic sections	26
4B.2.4.	Lower parts	28
4B.2.5.	Gauntlet track	29
4B.3.	Passengers train length	30
4B.4.	Freight train length	30
4B.5	Design speed for passengers' trains	31
4B.6.	Design speed for freight trains	31
4B.7.	Axle load	31
4B.8.	Double track	31
4B.9.	Level crossing	31
4B.10.	Gauge crossing with conventional railway network	31
4B.11.	Physical separation between Rail Baltica network and conventional network	31
4B.12.	Maintenance path	32

4B.13. Crosswind effect.....	32
4B.14. Control-command and Signalling.....	32
4B.15. Power supply and catenaries	32
4B.16. Interfaces with Rolling stock	32
5. Access.....	33
5.1. Access and Maintenance Roads.....	33
5.2. Principal schemes of Access and Maintenance roads	36
5.3. Main parameters.....	40
5.3.1. Geometrical parameters.....	40
5.3.2. Level of Service	40
5.3.3. Design vehicle model.....	40
5.3.4. Width of roads	41
5.3.5. Horizontal and vertical clearance	41
5.3.6. Widening of curve	42
5.3.7. Passing loops.....	43
5.3.8. Turnaround loop.....	43
5.3.9. Exit and entrance intersections	44
5.3.10. Road restraint systems	44
5.4. Requirements for pavement design	45
5.4.1. Basic requirements.....	45
5.4.2. Bearing capacity	45
5.4.3. Requirements for base course.....	45
5.4.4. Requirements for frost resistance layer	46
5.4.5. Requirements for drainage layer	47
5.4.6. Requirements for subgrade.....	47
5.4.7. Typical cross sections.....	49
5.5. Parking areas.....	50
6. Safety and Security	51
6.1. Fences	51
6.1.1. Common Provisions.....	51
6.1.2. Standard Fences	52

6.1.3.	"Sensitive Area" Fences	53
6.1.4.	Simplified Fences	53
6.2.	Alternatives systems.....	53
6.3.	Access Points.....	54
6.3.1.	Portals.....	54
6.3.2.	Safety Gates	54
6.3.3.	Movable Passages	55
6.4.	Fences on bridges and structures.....	55
6.4.1.	Types of fences	55
6.4.2.	Installing Fences in the Vicinity of Structures.....	55
6.5.	Fences for Electric Power Supply Substations	56
6.5.1.	Purpose of a Substation or Pylon Fence.....	56
6.5.2.	Fence Types.....	57
6.5.3.	Doors and Safety Gates.....	58
6.5.4.	Grounding.....	58
6.6.	Protective Devices on Road Bridges	58
6.6.1.	Devices to Prevent the Intrusion of Road Vehicles	59
6.6.2.	Vehicle Intrusion Detectors for Intrusion into Rights of Way	59
7.	Constraints for highway parallel to high speed line.....	60
7.1.1.	Twinning with high traffic routes.....	60
7.1.2.	Twinning with secondary roads	62
8.	Environmental conditions for systems.....	64
8.1.	Atmospheric pressure / Altitude	64
8.2.	Temperature.....	64
8.3.	Humidity	64
8.4.	Wind	64
8.5.	Surrounding air	64
8.6.	Rain	64
8.7.	Snow, ice and hail.....	65
8.8.	Solar radiation	65
8.9.	Lightning.....	65

8.10.	Pollution.....	65
8.11.	Vibration and shocks	65
8.12.	Fire protection	66
9.	Corrosion and exposure class.....	67
9.1.	Corrosion class for steel parts	67
9.2.	Exposure class for concrete parts	67
10.	Cableways.....	68
10.1.	Cableways on open line.....	68
10.2.	Cableways in Stations, Stopping points and Systems Equipment Locations	69
10.3.	General requirements.....	70
10.3.1.	Distance requirements.....	70
10.3.2.	Protection from ground and rainwater	72
10.4.	Conceptual solutions	73
10.4.1.	Cableways elements	73
10.4.2.	Minimum cableways system configurations.....	76
10.4.3.	Conceptual solution examples	76
11.	Design life.....	84
12.	Typical cross sections.....	85
13.	Tolerances for the construction.....	87
14.	Systems Equipment Locations.....	88
14.1.	System Equipment Location outside of station and stopping point areas	88
14.2.	System Equipment Locations in platform area.....	89
14.3.	System Equipment Locations in crossover and station turnout areas	90
APPENDIX 1: Technical specifications for the supply of multi-ducts, cable ducts, manholes and cable channels for construction of Rail Baltica railway line.....		92
Multiduct and Duct		93
Manhole incl. transition elements to Cable channel.....		94
Cable channel incl. straight, turned and elevated elements.....		94
Multiduct		96

Duct	97
Manhole	98
Cable channel	106
<i>Materials</i>	108
Interfaces	109
Cement	110
Aggregates	110
Concrete	110
Reinforcement	111
Security	111
Alkali-silica reactions	111
Design	112
Testing	112
Production Commencement	112
Routine production	114
5.2. Designation, description, marking and labelling of Goods shall be in according with appropriate product standards:	114
Installation, Storage, Maintenance manuals:	115
Drawings	116
Language	116
Manufacturing plants	116
Storage and transportation	117

1. Abbreviations

2G / 3G	2nd / 3rd Generation of Mobile communication systems
3GPP	3rd Generation Partnership Project
°C	Degree Celsius
A	Amp
AC	Alternative current
AFC	Automatic Fare Collection
AT	AutoTransformer

BHCA	Busy Hour Call Attempt
CAPEX	capital expenditure
CCS	Control Command Signalling
CCTV	Closed Circuit Television
CEDB	Compiled Energy Billing Data
CHT	Call Holding Time
CIQ	Control, Immigration, Quarantine
CT	Call Type
CWR	Continuous Welded Rail
D	Diameter
DC	Direct Current
DCS	Data Collecting system
DMO	Direct Mode
DMZ	Demilitarized Zone
DMS	Detectors Management system
DP	Danger Point
E&B	Earthing and Bonding
EIRENE	European Integrated Radio Enhanced Network
eLDA	Enhanced Location depending Addressing
EMI	Electromagnetic induction
EMC	Electromagnetic Compatibility
eMLPP	enhanced Multi-Level Precedence and Pre-emption
EN	European standard
ERA	European Railway Agency
eREC	enhanced Railway Emergency Call
ERTMS	European Railway Traffic Management System
ETCS	European Train Control System
ETCS_L2	European Train Control System - Level 2
FACP	Fire Alarm Control Panel
FN	Functional Number
FRMCS	Future Railway Mobile Communication System
FRS	Functional Requirements Specification
FBWM	flash butt welding machine
GC	Group Call
GCAREA	Group Call AREA
GMPLS	Generalized Multi-Protocol Label Switching
GPS	Global Positioning System
GSM-R	Global System for Mobile Communication
HMI	Human Machine Interface
HSL	High Speed Line
HSLM	High Speed Load Model
HSR	High Speed Rail
HO	Hand Over

HTTP	Hypertext Transfer Protocol
HV	High Voltage
HW/SW	Hardware / Software
HWL	High Water Level for 100-year return period
Hz	Hertz
IEC	International electromechanical commission
IP	Internet Protocol
IP-PABX	Internet Protocol-Private Automatic Branch exchange
IRMS	International Committee on Non-Ionizing Radiation Protection
ISO	International Standards Organization
IXL	Interlocking
Km/h	Kilometre/hour
KMC	Key Management Centre
kV	Kilovolt
LA	Los Angeles test (to measure resistance to fragmentation by shocks)
LDA	Location depending Addressing
LED	Light-Emitting Diode
Li-Fi	Light Fidelity
LOS	Level of Services
LTE	Long Term Evolution
LV	Low voltage
m	Meter
MBV	Methylene Blue Test Value
MDE	Micro-Deval test (to measure resistance to wear)
MEP	Mechanical, Electrical and Plumbing
MIMO	Multiple Input Multiple Output
MMS	Maintenance Management System
MOS	Mean Opinion Score
MTA	Mail Transfer Agent für Unix und Unix-Derivate
MTBF	Mean Time Between Failures
MTTR	Mean Time To Repair
MV	Medium Voltage
NF	Negative Feeder
NMS	Network Management Systems
NSA	National Safety Assessor
NTP	Network Time Protocol
NTPS	Non Traction Power Supply
OCC	Operation Control Center
OCL	Overhead Catenary Line
OCR	Optical Character Recognition
OCS	Overhead Catenary system
OPEX	Operational expenditure

OPM	Optimum Proctor Modified
OSI- Model	Open Systems Interconnection Model
OTA	Over The Air
OWASP	Open Web Application Security Project
PAS	Public Address System
PC	Personal Computer
PIDS	Passenger Information Display System
PKI	Public Key Infrastructure
PLC	Programmable Logic Controller
PoE	Powered over Ethernet
PP	Paralleling posts
PS	Power Supply
PSD	Platform screen doors
PTT	Push To Talk
PTZ	Pan Tilt Zoom
QoS	Quality of Service
RAM	Reliability Availability Maintainability
RBC	Radio Block Centre
REC	Railway Emergency Call
RF	Radio Frequency
RFC 8	Rail Freight Corridor 8
RFC NS-B	Rail Freight Corridor North Sea - Baltic
RMS	Railway Management System
RoHS	Restriction of Hazardous Substances
ROW	Right of Way
RTU	Remote Terminal Units
SCADA	Supervisory Control and Data Acquisition
SIG	Signalling
SIM card	Subscriber Identity Module card
SMS	Short Message Service
SR	Staff Responsible
SRS	System Requirements Specification
SS	SubStation
SWP	Switching posts
t	Ton
TC	Track circuit
TES	Traction Electrification System
TMS	Traffic Management System
TN-S	Earthing system
TOR	Terms of Reference
TPS	Traction Power Supply
TSI	Technical Specification for Interoperability
TSR	Temporary Speed Restriction

TSS	Traction SubStation
TVF	Tunnel Ventilation Fans
TVD	Tunnel Ventilation Dampers
TVM	Ticket vending machine
TVO	Ticket vending office
UIC	Union Internationale des Chemins de Fer / International railway union
UMTS	Universal Mobile Telecommunications System
UPS	Uninterruptible Power Supply
USE	Upper Section of Earthworks
V	Volt
VBS	Voice Broadcast Service
VGCS	Voice Group Call Service
Wi-Fi	Technology for wireless networking
WP	Work Package

2. Standards and specifications

2.1. Specifications applicable for the Design Guidelines

Technical specifications for Interoperability applicable for the Design Guidelines are:

Title	Abbreviation	Signature date	Publication date	Application date
Commission Decision 2012/757 / EU of 14 November 2012 - Traffic Operation and Management TSI	OPE TSI	08/06/2015	30/06/2015	01/07/2015
Commission Regulation (EU) 2016/919 of 27 May 2016 - Control-Command and Signalling TSI	CCS TSI	27/05/2016	15/06/2016	05/07/2016
Commission Regulation (EU) No 1299/2014 of 18 November 2014 - Infrastructure TSI	INF TSI	18/11/2014	12/12/2014	01/01/2015
Commission Regulation (EU) No 1300/2014 of 18 November 2014 - TSI "Accessibility for disabled persons and persons with reduced mobility"	PRM TSI	18/11/2014	12/12/2014	01/01/2015
Commission Regulation (EU) No 1301/2014 of 18 November 2014 - Energy TSI	ENE TSI	18/11/2014	12/12/2014	01/01/2015
Commission Regulation (EU) No 1302/2014 of 18 November 2014 - TSI "Rolling stock - Locomotives and rolling stock for the carriage of passengers"	LOC & PAS TSI	27/05/2016	15/06/2016	05/07/2016
Commission Regulation (EU) No 1303/2014 of 18 November 2014 - TSI "Safety in railway tunnels"	SRT TSI	18/11/2014	12/12/2014	01/01/2015
Commission Regulation (EU) No 1304/2014 of 26 November 2014 - TSI "Rolling Stock - Noise"	NOI TSI	26/11/2014	12/12/2014	01/01/2015
Commission Regulation (EU) No 1305/2014 of 11 December 2014 - TSI "Telematic applications for freight"	TAF TSI	11/12/2014	12/12/2014	01/01/2015
Commission Regulation (EU) No 321/2013 of 13 March 2013 - TSI 'rolling stock - freight wagons'	WAG TSI	08/06/2015	17/06/2015	01/07/2015
Commission Regulation (EU) No 454/2011 of 5 May 2011 - TSI 'Telematic applications for passengers'	TAP TSI	25/02/2015	26/02/2015	18/03/2015

Following directives shall be considered:

2004/49/EC of April 29, 2004 on safety on the Community's railways and amending Directive 95/18/EC of the Council,	on licensing of railway enterprises
2004/50/EC of June 1, 2007 amending Annex VI to Directive 96/48/EC	of the Council, on the Interoperability of the Trans-European high-speed railway system
2007/32/EC of June 1, 2007 amending Annex VI to Directive 96/48/EC of the Council	on the Interoperability of the Trans-European high-speed railway system and amending Annex VI to Directive 2001/16/EC of the European Parliament and the Council, on the Interoperability of the Trans-European high-speed railway system;
2008/57/EC of June 17, 2008	on interoperability of the rail system within the Community, into force as of June 19, 2010 (repealing Directives 96/48/EC and 2001/16/EC from 19 July 2010). Directive (EU) 2016/797, article 58: "Article 58 – Repeal - Directive 2008/57/EC, as amended by the Directives listed in Annex V, Part A, is repealed with effect from 16 June 2020, without prejudice to the obligations of the Member States relating to the time limits for the transposition into national law of the Directives set out in Annex V, Part B. References to the repealed Directive shall be construed as references to this Directive and shall be read in accordance with the correlation table in Annex VI. "
2012/34/EU of 21 November 2012	establishing a single European railway area
REGULATION No 1371/2007	on rail passengers' rights and obligations
2016/364 of 1 July 2015	Classification of the reaction to fire performance of construction products
2016/797 of 11 May 2016	on the interoperability of the rail system within the European Union

2.2. Specific standards related to General requirements

EN Standards:

EN15273-1, EN15273-2 and EN15273-3 Railway applications - Gauges

EN1317-1 and EN1317-2 Road restraining systems

EN206 Concrete - Specification, performance, production and conformity

EN50125-2 and EN50125-3 Railway applications - Environmental conditions for equipment

IEC 60529 Degrees of protection provided by enclosures (IP Code)

EN50124-1 and EN50124-2 Railway applications - Insulation coordination

EN 12094 Fixed firefighting systems - Components for gas extinguishing systems

EN ISO9223 Corrosion of metals and alloys - Corrosivity of atmospheres - Classification, determination and estimation

UIC recommendations:

IRS 60-661 – Ed.1 Railway application – High speed. Dynamic integration tests and trial operation before revenue operation

UIC 777-1 R "Measures to prevent impacts by road vehicles against rail bridges and to prevent the penetration of vehicles onto the track"

3. Design standard classification

The following terms are used to classify the criteria:

- Recommended or nominal value: Standard to be achieved (must be equal or better than the stated requirement), provided that there are no major technical, cost or schedule constraints. Designers shall use 'Recommended' or 'Nominal values' to the extent practical. In case the Designer applies these values where the technical, cost or schedule constraints exist and could be arguable, the Designer shall clearly indicate such constraints and provide justification as to why the solution should be implemented.
- Minimum/Maximum or limited value: Represent limits and/or ranges of allowable values. Designers shall make every effort to avoid the use of ranges for values and to instead use specific values. Minimum/Maximum values and ranges are acceptable only in circumstances where 'Recommended' values are impractical to apply due to particular constraints.
- Exceptional values: These are extreme values, that differ from the standard design approach, and that may only be used under highly restricted conditions where 'limited values' can not be applied for the purpose of achieving an acceptable solution. Any application of 'exceptional values' in the design process requires the prior approval of RB Rail AS.
- "Shall": Indicates mandatory requirement that must be strictly implemented. Any impossibility to fulfill this requirement must be agreed through a derogation case (see change management procedure).

- “Should”: Indicates preferred course of action, recommendations. No agreement of derogation is necessary, there may exist valid reasons in particular circumstances to ignore a particular item, but the full implications must be understood and carefully weighed before choosing a different course - for example the same goal is reached by other solutions, which are permissible within the binding standards or documents.
- “Must”: Indicates an obligation or a mandatory requirement.
- “May”: Indicates a permissible course of action within the limits of the standards, but which is not mandatory to be fulfilled.

The design standard classification shall be read jointly with RBDG-MAN-011 Change management Procedure

4. Part A: General operational requirements

4A.1. Line operational principles

The Rail Baltica line shall be a mixed traffic high speed line, which shall accommodate operation of freight and passengers' trains on a simultaneous manner.

The Rail Baltica line shall be equipped with double track, except sections with limited traffic or temporary situation.

The stations on Rail Baltica line should be designed on a symmetrical manner.

The North – South direction shall be defined as the even direction, and the South-North direction is defined as odd direction.

The normal train direction is the right hand-side, the contraflow direction the left hand-side.

The Rail Baltica line should allow operation on both directions at same speed.

The Rail Baltica line shall allow the operation of trains on the same direction on parallel tracks, with trains authorised at their nominal speeds.

The Rail Baltica line shall allow the dynamic overtaking of trains.

The commercial trains operated on Rail Baltica line shall be equipped with ERTMS system.

4A.2. Speed definitions

Design speed: *speed permitted by track geometry parameters at a particular point.* Space graph of design speed is the design speed profile. Design speed profile is defined by track parameters values, with abrupt changes.

Operation speed: *speed which could be reached by a typical type of train at a particular point.* Space graph of operational speed is the operational speed profile. Operation speed profile is a continuous function without abrupt changes, representing the physical speed of a train.

Maximum operation speed: *operation speed inferior or equal to the Design speed.*

Nominal operation speed: *operation speed which shall be considered as typical for a particular type of train.* Nominal operation speed is used to calculate timetable.

Maximum revenue operation speed: *defined if different from maximal operation speed for a specific period.*
(IRS 60661-Ed.1)

Maximum test speed: *under feasible conditions, the setting of the maximum test speed for each section of the line should be higher or equal to the maximum revenue operation speed for this section on a near futur, while no more than 110% of the maximum design speed for this section* (IRS 60661-Ed.1)

4A.3. Passenger trains

The Rail Baltica line shall allow the operation of all types of passengers' trains compliant with Rolling Stock - Locomotives and Passengers TSI (LOC & PAS TSI).

The Rail Baltica line shall be designed targeting operation of the following passengers' train services:

- High speed trains
- Night trains
- Regional express trains

High speed trains shall be operated at the nominal operational speed of 249 km/h. Where track alignment allows and all necessary conditions are met, high speed trains may be operated at higher maximum operational speed, up to 300 km/h.

Night trains shall be operated at the nominal operational speed of 200 km/h. Exceptionnaly, operational speed of 160 km/h could be accepted, for the case of night train with car carrier wagons, if impact on overall traffic is limited.

Regional trains shall be operated at the nominal operational speed of 200 km/h.

The nominal lenght of high speed and night train compositions shall be 400 m maximum.

The nominal lenght of regional train compositions shall be 200m maximum.

4A.3. Freight trains

The Rail Baltica line shall allow the operation of all types of freight trains compliant with Rolling Stock - Locomotives and Passengers TSI (LOC & PAS TSI).

The Rail Baltica line shall allow operation of freight trains composed of locomotives and wagons with SEc gauge, as defined in Swedish Infrastructure Manager Trafikverket document TRVINFRRA-00398, refer to chapter 4B.1.). The operation of SEc trains shall be possible on all mixed traffic lines, with same nominal operational speeds than for GC trains, and with minimal operational limitations.

The Rail Baltica line should allow operation under exceptional consignment rules of freight trains with one or several exceptional parameters:

- Height,
- Width,
- Wagon length
- Long elements loaded on several wagons,
- Axle load
- Heavy load.

Standard freight trains shall be operated at the nominal operational speed of 100 km/h, with maximum operational speed of 120 km/h.

Fast intermodal trains (containers) shall be operated at the nominal operational speed of 120 km/h. Where track alignment allows and all necessary conditions are met, fast intermodal trains (containers) may be operated at higher maximum operational speed, up to 140 km/h.

Piggybacking trains (rolling motorway for semi-trailers) shall be operated at the nominal operational speed of 120 km/h.

The maximal length of freight train compositions shall be 1050m.

The maximal axle load of freight train shall be 25 tons.

4. Part B: General infrastructure requirements

The Rail Baltica line shall accommodate passengers' trains classified as P2 traffic code and freight trains classified as F1 traffic code.

4B.1 Gauge

According to to INF TSI 4.2.1, the design shall be done considering kinematic reference profile GC for all the line, as it is defined in EN15273-3 Annex C, §C.2.3.

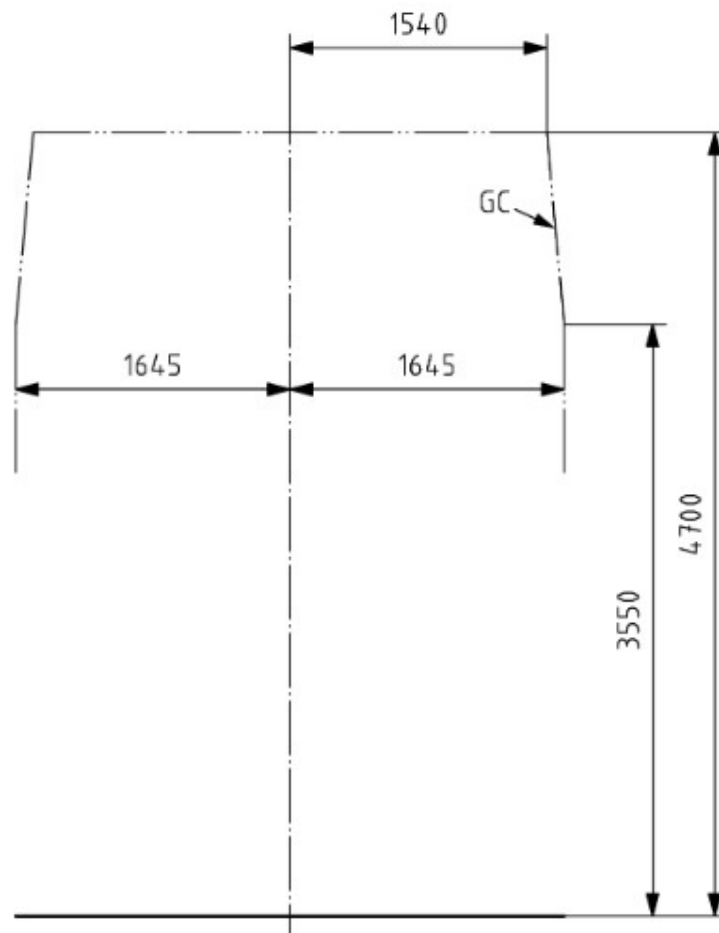

FIGURE 1 KINEMATIC REFERENCE PROFILE GC

Additionally, for the Mixed Traffic Line sections (Refer to RBDG-MAN-013-0102_RailwayAlignment), wider and higher gauge shall be considered for the upper and middle gauge parts, to allow overgauge exceptional transport and operation under exceptional procedures of wagons, resulting from dynamic reference profile SEc (As defined in Swedish Infrastructure Manager Trafikverket document TRVINFRA-00398, see Figure 2).

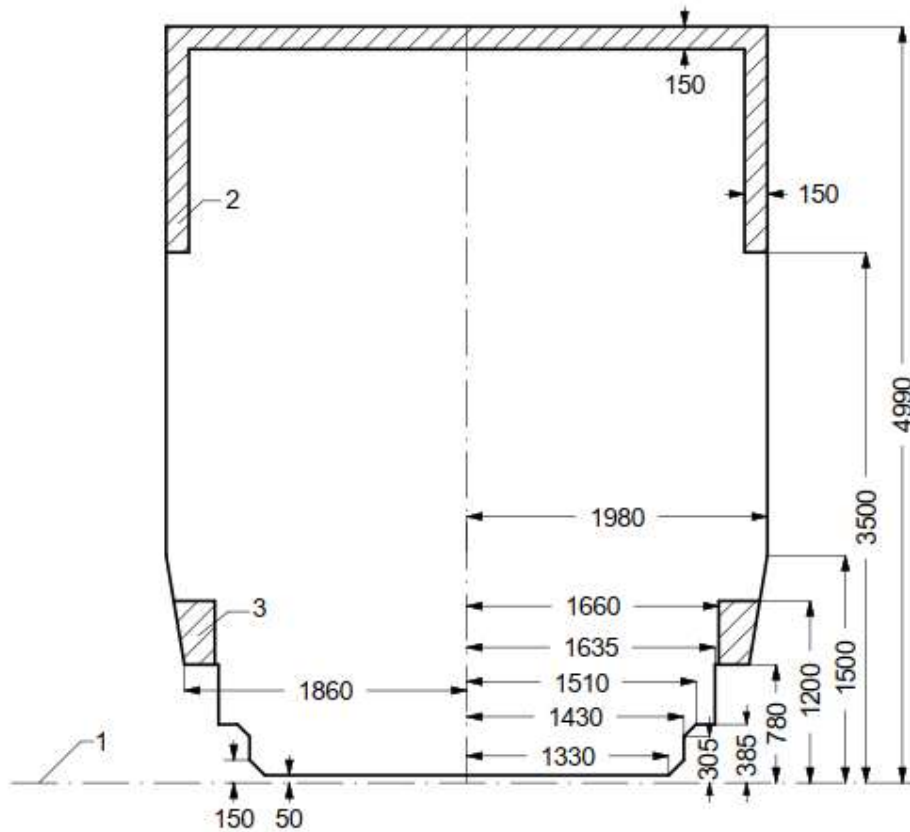

FIGURE 2 DYNAMIC REFERENCE PROFILE SEC (EXTRACT FROM TRVINFRA-00398)

1-TOR

2-Zone into which the non-insulated parts likely to remain live shall not penetrate (150mm for 15kV)

3-Vehicles that operate next to loading platforms shall not use this area

Considering the use of low floor wagons for the whole line, additional requirements for the lower part to be followed are defined in EN15273-2- scheme for G13 kinematic reference profile.

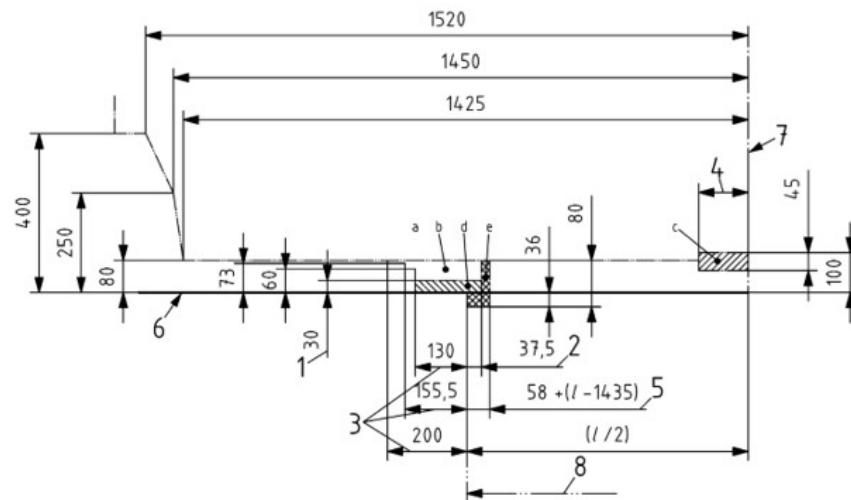

- a zone for parts away from the wheels
- b zone for parts in the immediate proximity of the wheels
- c zone for contact ramp brushes
- d zone for wheels and other equipment coming into contact with the rails
- e zone occupied exclusively by the wheels
- 1 limit, not to be exceeded, of parts located outside the end wheelsets (guard-irons, sanders etc.) for passive over detonators. However, this limit need not be adhered to by parts located between the wheels as long as these latter remain within the path of the wheels
- 2 maximum theoretical width of the flange profile in the case of the check rails
- 3 effective limit position of the wheel outer face and of the parts associated with the wheel
- 4 when the vehicle is in any position whatsoever on a curve of radius $R = 250$ m (minimum radius for contact ramp position) and a track width of 1,465 m, no part of the vehicle likely to descend to less than 0,100 m above the running surface, except for the contact brush, shall be less than 0,125 m from the track centreline. For bodies mounted under the bogies, the space to be cleared is also fixed at 0,150 m
- 5 effective limit position of the inside surface of the wheel when the opposite wheel is in flange contact. This dimension varies with track gauge widening position
- 6 running surface
- 7 centreline of the reference profile
- 8 internal rail surface

FIGURE 3 EXTRACT FROM EN15273-2 ANNEX D FOR GI3 KINEMATIC GAUGE

4B.2. Structure gauges

No track-side equipment shall be located inside the structure gauge (signals, catenary masts...). Platforms may extend into the structure gauge within area B (see Figure 7 Mixed traffic sections Structure gauge and Figure 9 Passengers only and light freight traffic sections Uniform Structure gauge), up to the respective installation limit gauge according to the kinematic or dynamic reference profile boundary.

The structure gauge for passenger only and light freight traffic sections presented in Figure 9, is calculated using the kinematic method in accordance with the requirements of sections 5,7, 10 and Annex C of EN15273-3:2013.

The structure gauge for mixed traffic sections presented in Figure 7, is taking into account GC kinematic method as described above and additionally, the Normalsektion and Minsta Sektion from TRVINFRA-00398 for compatibility with Sec dynamic gauge.

4B.2.1. Pantograph

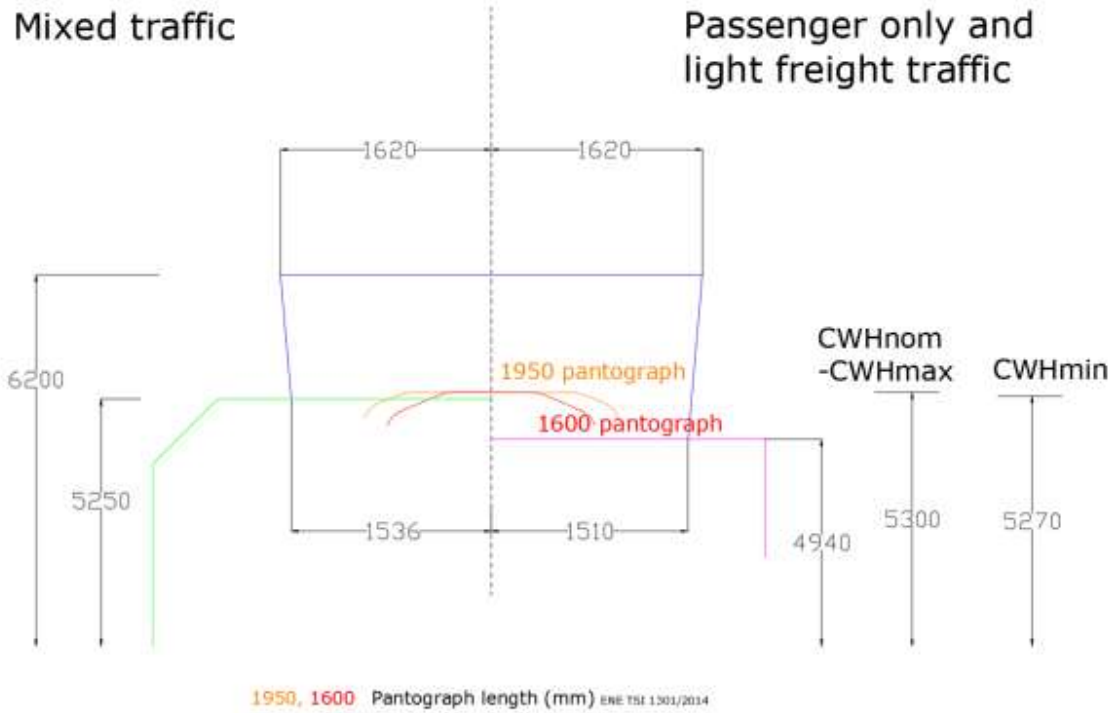

TRAFFIC	min CWH	nom CWH	max CWH
MIXED	5.27 m	5.30 m	5.30 m
PASSENGER -LIGHT FREIGHT	5.27 m	5.30 m	5.30 m

FIGURE 4 PANTOGRAPH STRUCTURE GAUGE

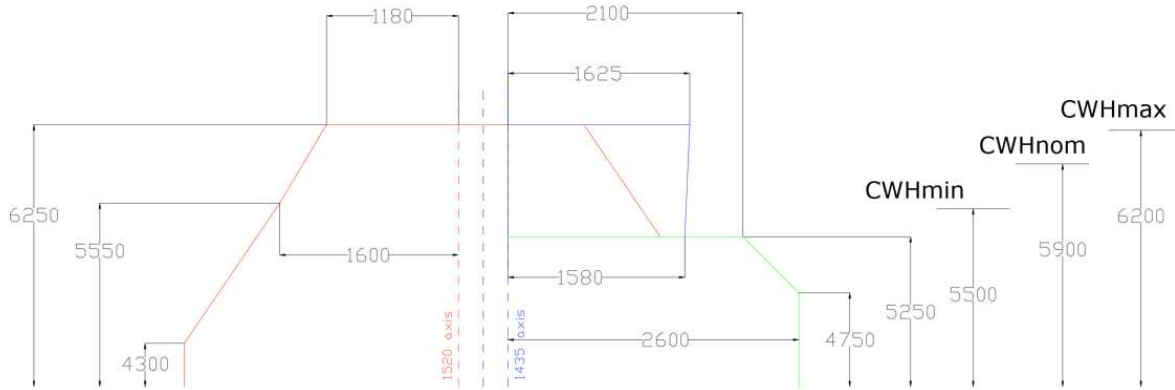

FIGURE 5 PANTOGRAPH STRUCTURE GAUGE FOR GAUNTLET 1520 AND 1435 MIXED TRAFFIC SECTIONS

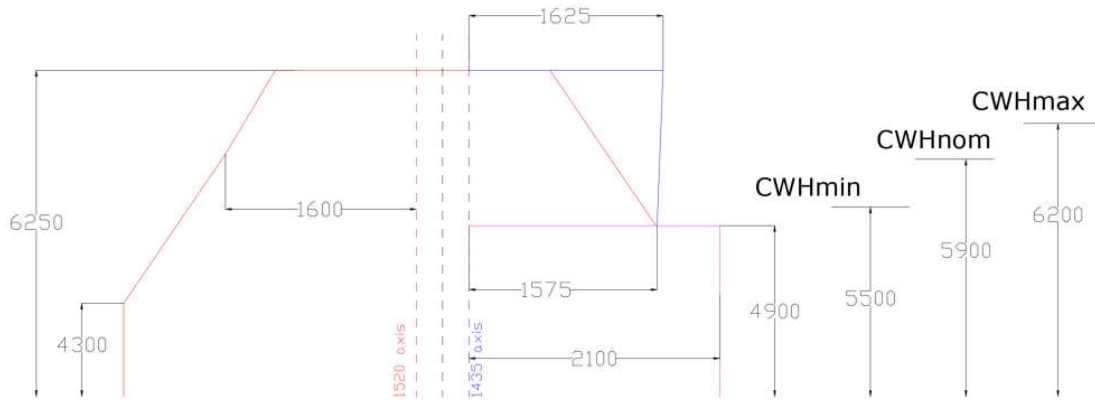
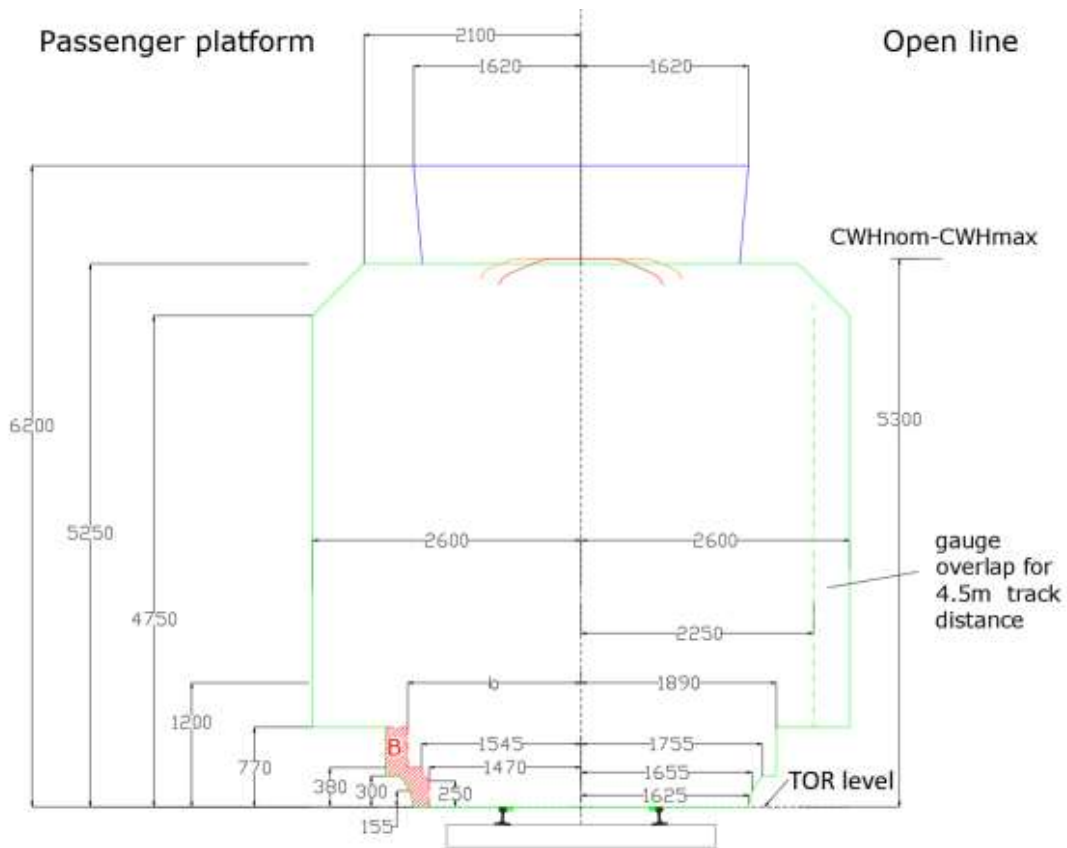

FIGURE 6 PANTOGRAPH STRUCTURE GAUGE FOR GAUNTLET 1520 AND 1435 PASSENGER ONLY AND LIGHT FREIGHT TRAFFIC SECTIONS

4B.2.2. Mixed traffic sections



B Space for passenger platform

- b 1675 mm at straight
- 1675 + U_i/y according to formula (1), (2) at curve

Extension in curves

Inner side of curve

$$U_i = 41000/R \quad (1)$$

Outer side of curve

$$U_y = 31000/R \quad (2)$$

Inclination in canted sections

$$H = D \cdot y / 1500 \quad (3)$$

$$V_{\pm 1/2} = D \cdot (B_{\pm 1/2} \pm 750) / 1500 \quad (4)$$

- U_i*: Gauge widening in the inner side of the curve (mm)
- U_y*: Gauge widening in the outer side of the curve (mm)
- R*: Horizontal radius (m)
- H*: Horizontal displacement of the gauge profile at a certain point (mm)
- V*: Vertical displacement of the gauge at a certain point (mm)
- D*: Applied cant (mm)
- y*: Height from TOR of the point where the displacement is calculated (mm)
- B*: Semi width of the gauge at the point where the displacement is calculated (mm)

FIGURE 7 MIXED TRAFFIC SECTIONS STRUCTURE GAUGE

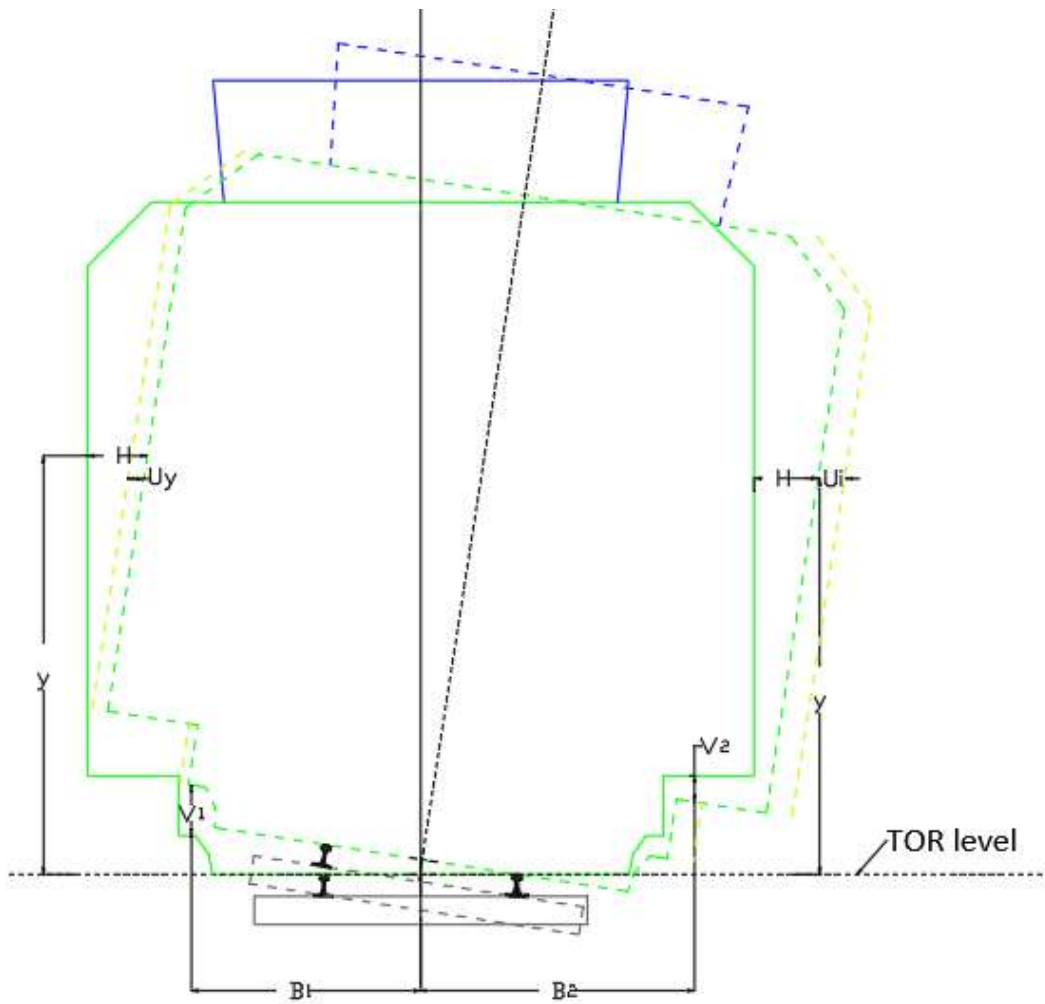
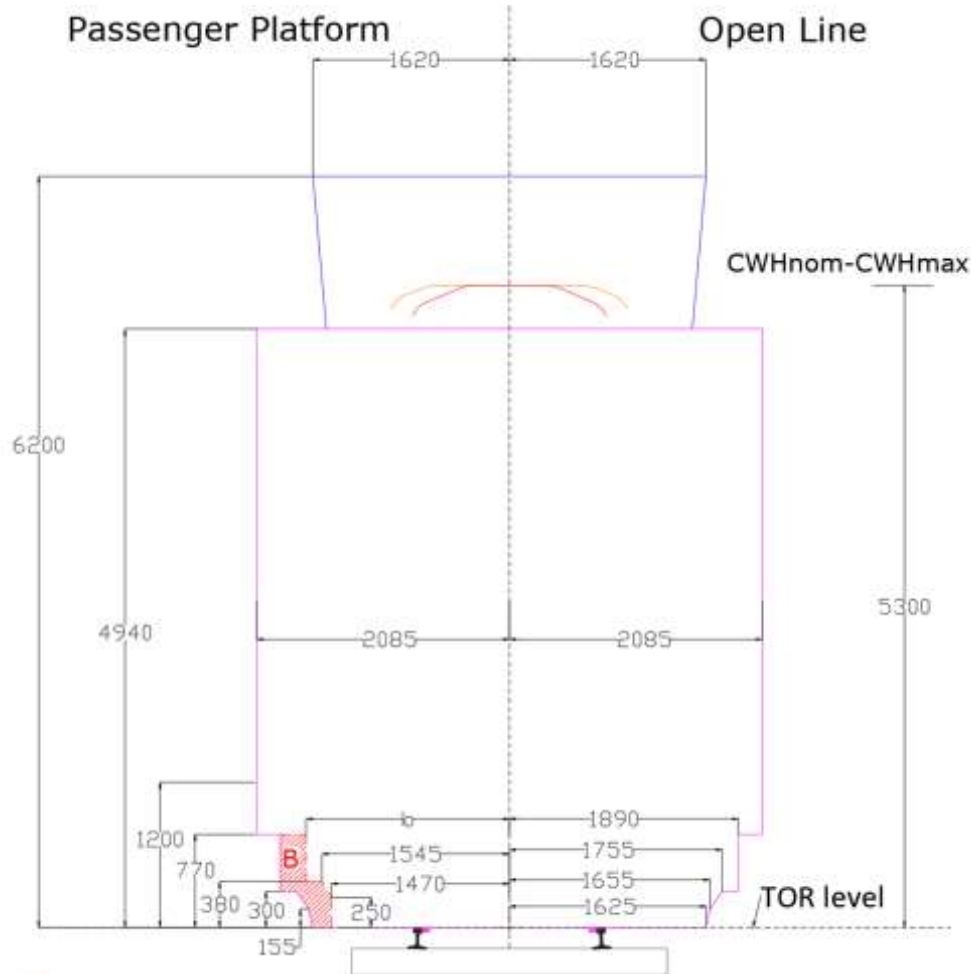

FIGURE 8 EXTENSION AND INCLINATION IN MIXED TRAFFIC SECTIONS ON RADIUS WITH CANT

4B.2.3. Passengers only and light freight traffic sections



B Space for passenger platform

b 1675 mm at straight

1675 + U_i/y according to formula (1), (2) at curve

Inclination in canted sections

$$H = D * y / 1500 \quad (3)$$

$$V_{1/2} = D * (B_{1/2} \pm 750) / 1500 \quad (4)$$

H: Horizontal displacement of the gauge profile at a certain point (mm)

V: Vertical displacement of the gauge at a certain point (mm)

D: Applied cant (mm)

y: Height from TOR of the point where the displacement is calculated (mm)

B: Semi width of the gauge at the point where the displacement is calculated (mm)

FIGURE 9 PASSENGERS ONLY AND LIGHT FREIGHT TRAFFIC SECTIONS UNIFORM STRUCTURE GAUGE

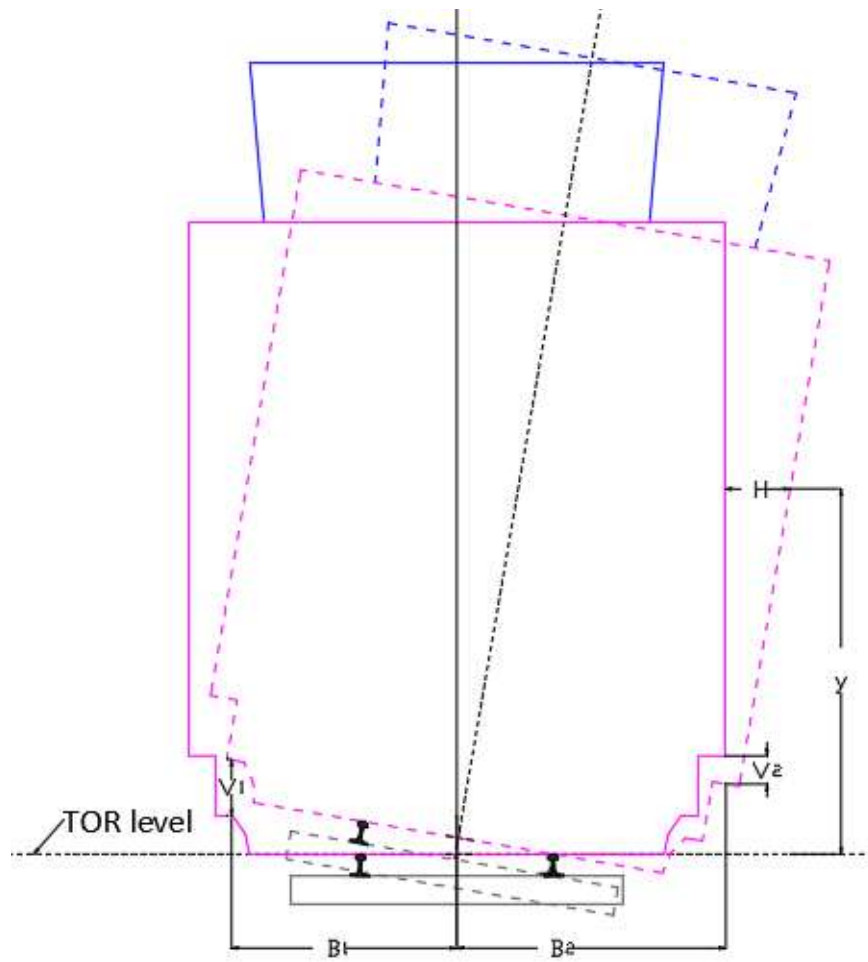

FIGURE 10 INCLINATION IN PASSENGER ONLY AND LIGHT FREIGHT TRAFFIC SECTIONS ON RADIUS WITH CANT

4B.2.4. Lower parts

The lower parts of the structure gauges for Passenger only and Light Freight traffic and Mixed traffic, are compatible with G13. The lower gauge according to the Swedish standard TRVINFRA-00398 for the free space up to 50mm above TOR is not considered for RB network. Operational rules defined by the infrastructure manager will apply for allowing SEc traffic in the network. The exact dimensions for lower gauge depend on the horizontal and vertical characteristics of the line and shall be defined according to the respective geometry in each stretch, based on the formulas for the kinematic method from EN15273-1, 2, 3.

Passenger platform

Open line

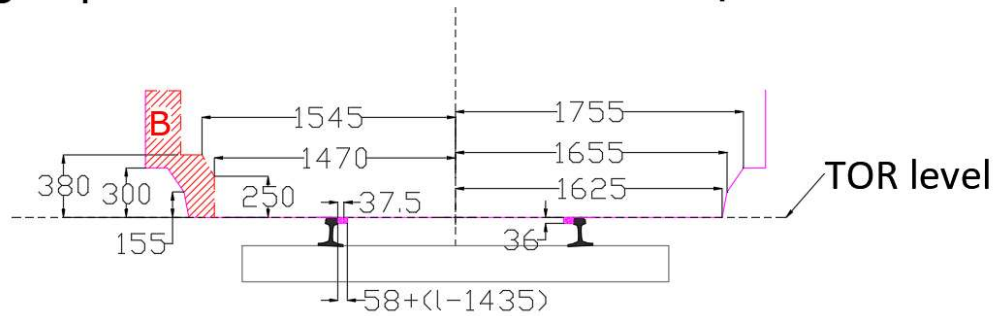

FIGURE 11 LOWER PARTS OF THE STRUCTURE GAUGE FOR MIXED TRAFFIC AND PASSENGER ONLY AND LIGHT FREIGHT TRAFFIC SECTIONS

4B.2.5. Gauntlet track

Structure gauge for gauntlet track of 1520 and 1435 on straight sections is presented in figures 10 and 11. The rules for additional widenings on curved stretches to be applied, shall be according to chapters 4.2.2 and 4.2.3 for 1435 and the respective 1520 national rules.

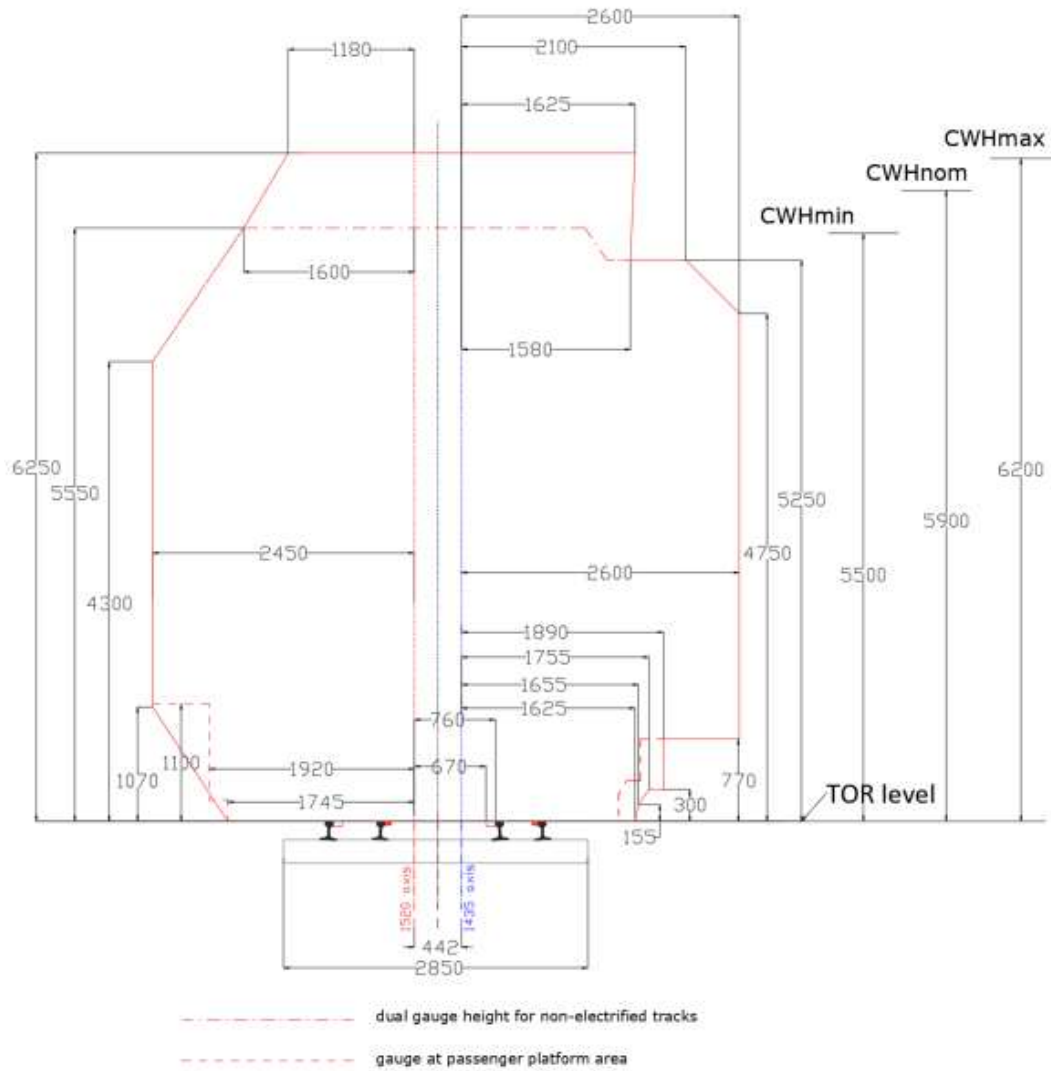

FIGURE 12 GAUNTLET TRACK STRUCTURE GAUGE FOR 1520 AND 1435 MIXED TRAFFIC SECTIONS

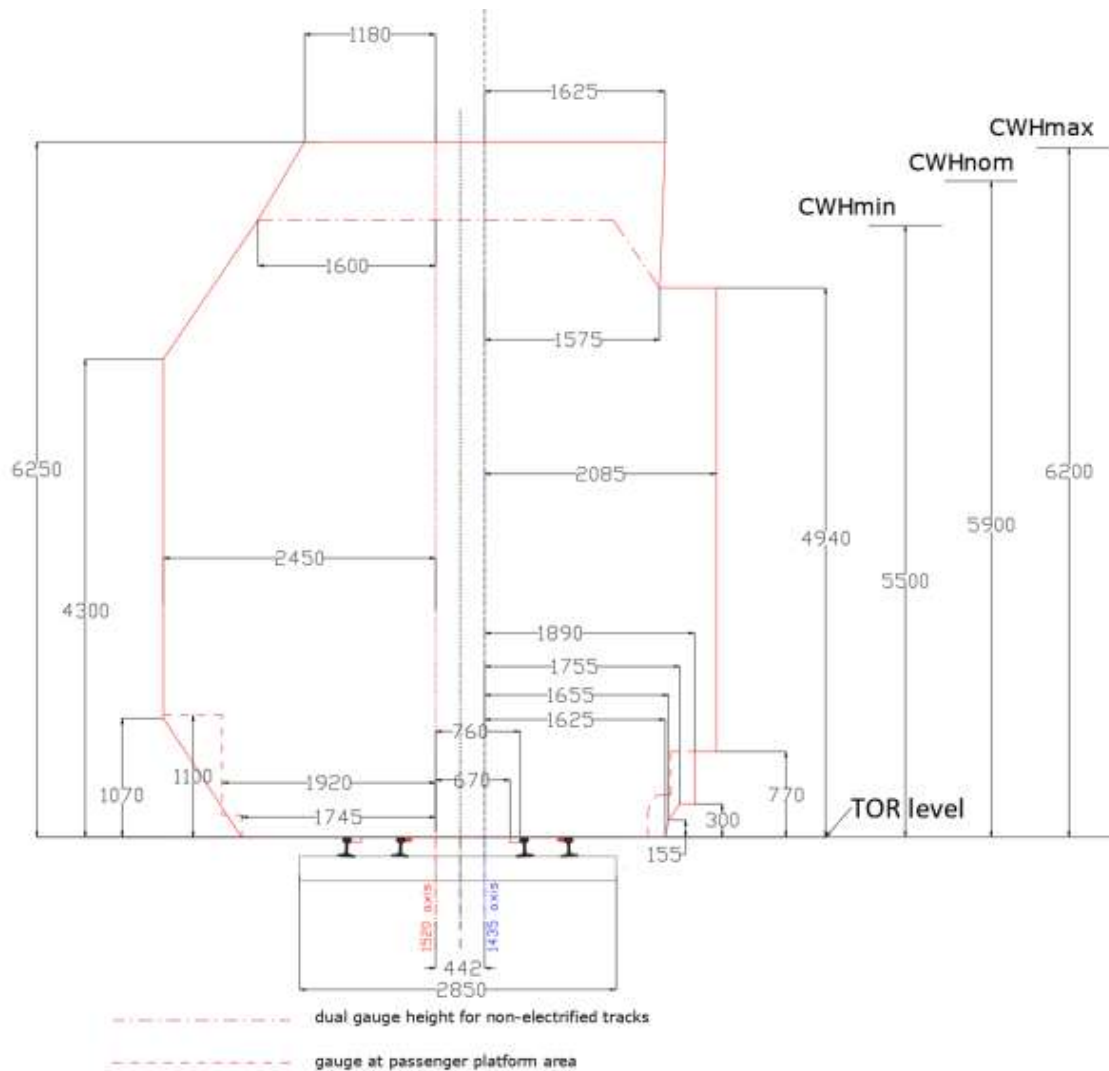

FIGURE 13 GAUNTLET TRACK STRUCTURE GAUGE FOR 1520 AND 1435 PASSENGER ONLY AND LIGHT FREIGHT TRAFFIC SECTIONS

4B.3. Passengers train length

The design shall be done considering passenger train length of 400m for all infrastructure except the passenger platform which can be designed for 200m.

If the passengers' platform is part of an elevated structure, the designer shall provide technical and economical comparison between 200m elevated structure to be upgraded to 400m later and 400m elevated structure build since the beginning of the project for client decision.

4B.4. Freight train length

The design shall be done considering freight train length of 1050m for all infrastructure.

For existing infrastructure, the designer shall provide technical and economical comparison between existing infrastructures to be upgraded to 1050m after Rail Baltica line construction completion and existing infrastructures upgraded to 1050m during Rail Baltica line construction for client decision.

4B.5 Design speed for passengers' trains

The design shall be done with a design speed for passengers' trains of 249km/h for the main line with mixed traffic (passengers and freight trains).

The design shall allow for sustained operating speed of 234km/h

4B.6. Design speed for freight trains

The design shall be done with a design speed for freight train of 120km/h for the main line.

4B.7. Axle load

The design shall be done with an axle load of 25t for all the line.

4B.8. Double track

The design shall be done considering double track for all the main line.

4B.9. Level crossing

No level crossing shall be designed on the Rail Baltica main line. Level crossings are allowed only in areas with no passenger traffic and low speed (40km/h maximum) such as depot, multimodal terminal.

4B.10. Gauge crossing with conventional railway network

No gauge crossing with conventional railway network (1435mm and 1520mm) shall be designed on the Rail Baltica line.

Gauge crossing, or mixed gauge tracks are allowed in dedicated freight stations, with speed not exceeding 40 km/h.

4B.11. Physical separation between Rail Baltica network and conventional network

A physical separation shall be visible for maintenance team between the Rail Baltica network and the conventional network. The minimum physical separation is a fence of 1.1 m height.

4B.12. Maintenance path

Maintenance path of 0.8m width is required on both side of the main line. The maintenance path shall not be closer than 2.70m from the track centre on the main line (exceptional value) and shall not be interrupted by catenary masts. The nominal distance is 3.0m and this value shall be applied in all locations without right of way constraints.

In depots and multimodal terminals, the minimum distance from the track centre to the maintenance track is 2.0m.

4B.13. Crosswind effect

Crosswind effect shall be checked as per INF TSI chapter 4.2.10.2 and EN 14067-6.

4B.14. Control-command and Signalling

The signalling system will be based on ERTMS of level at least 2, baseline 3, without trackside signals.

Bi-directional signalling shall be designed on the whole line to facilitate operations and allow same operational speed on both directions and dynamic overtaking.

4B.15. Power supply and catenaries

Standard power supply shall be provided with 2x25kV – 50 Hz.

All equipment shall be monitored and controlled from national Power Supply Operation Control Centre (PSOCC) through an Overhead Control System (OCS) with a SCADA (Supervisory Remote Control and Data Acquisition System) microprocessor-based system.

4B.16. Interfaces with Rolling stock

The Rolling stock used for the project shall be in full compliance with TSI criteria and no specific rolling stock is forecast on Rail Baltica line (no specific pantograph, full ERTMS).

The use of Eddy current brakes is not considered on Rail Baltica line.

5. Access

Roads design solutions shall be done in way to provide cost-effective and environmentally friendly solutions to provide the safety for road users and ensure essential road conditions throughout the design working life of the road. The consultant shall carry out all the necessary site investigations, surveys, geodetic and topography, geological, geotechnical and hydro-geology, hydrology, noise, environmental and any other investigations necessary to provide sufficient output data to develop design solutions in modern and on best examples of practice based style. The consultant is responsible to receive responsible authorities/institutions approvals in accordance with applicable national legislation, regulations and standards. In addition, designer shall follow the Operational plan, Infrastructure Maintenance Facility study, Design Guidelines, Utilities Requirements, Architecture, Landscape and Visual Identity design Guidelines.

As far as possible, the designer shall consider improving existing roads instead of constructing new ones. As far as it is reasonable, the design solutions (particularly plan solutions) for access roads shall be designed to provide suitable accessibility to the adjacent railway infrastructure in way to cover functions of maintenance roads.

5.1. Access and Maintenance Roads

Access roads

Access Roads are for public use and shall be foreseen to provide access to land plots, forest roads, local roads and households etc. where previous access has been cut due to the railway line. Access road technical parameters for pavement calculations and geometry shall be chosen by following criteria:

- access roads that do not lead to any maintenance road entrance shall be designed according to national legislation, standards, regulations from roads owners or governors or other institutions and traffic survey results;
- access road technical parameters for a road section prior to the entrance of a maintenance road shall be equal to or higher than the maintenance road category parameters (see Table 1).

Maintenance roads

Maintenance roads shall be designed only if it is impossible to provide access from the public roads network to railway infrastructure and/or for emergency services. Access shall be designed leading to specific infrastructure (switches, signaling cabinets, sub-stations, etc.) as close as possible. Maintenance roads shall be located inside the highspeed railway right of way. Maintenance roads shall not be open for public use. Maintenance roads shall be designed as a non-continues roads. **Detailed maintenance road layout principles shall be agreed by the Client.** If maintenance roads aren't provided on both sides of the railway line, then signaling and safety equipment shall be provided on the line to allow safe crossing of maintenance and/or emergency services teams. At the dead-end of maintenance road turnaround loop shall be foreseen. Axle loads for maintenance roads shall be chosen by Table 1 and recommended geometrical values are shown in paragraph 5.3.

Maintenance roads shall be designed to provide access to all the following railway infrastructure:

- Stations (Category I)
- Passing loops (Category I)
- Turnout areas (Category I)
- Embankment for heavy inspection equipment (Category I)
- Embankment for substations and on-line AT boxes (Category I)
- Signalling systems (Category II)
- Radio sites (Category II)
- Hot box detector embankment (Category II)
- All low voltage equipment on the embankment (Category II)
- Embankment for light inspection equipment (Category II)
- Embankment for positioning inspection catwalks or gantries for structures if maintenance is forecasted using such system (Category II)
- Each side of the high-speed line at both ends of all tunnels (Cat. II in additional to any potential Cat. I roads)
- Each side of the high-speed line adjacent to all structures (Category II).

Some sites or parts of structures may require some specific Category II roads if the roads provided for the special points above cannot serve them:

- Instrumented sites;
- Landscaped sites;
- Gravel traps for rocky embankments;

- Berms on the slope of embankment (to remove gravel from rocky slopes, maintain drainage ditches, etc.);
- Retention basins, small hydraulic structures, berm drainage, etc.

Maintenance roads are divided in two categories which differs from each other by maximum design axel load shown in Table 1. Principal schemes of access and maintenance roads are shown in paragraph 5.2..

Typical installation of maintenance road is in drawing RBDG-DWG-065-A2.

Category	Main function	Max designed axle load
I	Maintenance road	11,5 t- per axle
II	Maintenance road	3,5 t per axle
Access road	for public use	According to national regulations and legislation or maintenance road category

TABLE 1: ACCESS AND MAINTENANCE ROAD CLASSIFICATION

Green paths:

Green path is defined as a 4,0m wide area between outer edge of ditch and enclosure shown on drawing RBDG-DWG-001-A6. Green path may be used by maintenance vehicles (weight up to 3.5t, length up to 6,0m) to provide maintenance services only for culverts, noise barriers, fences and railway ditches. Usage of green path for maintenance purposes for prior mentioned structures is allowed only in exceptional cases with Client's approval and relevant National Implementing Body's approval. Designer for such situations must provide justifications and evaluate the need of green path reinforcement.

Green paths used for maintenance purpose shall not be located in flooded area. Green paths shall be located next to railway ditch. In addition, Consultant shall take into account that green paths may be used by maintenance crew only on dry seasons (june – august) or during winter time when ground is frozen. Green paths shall be levelled to provide accessibility and all necessary maintenance procedures shall be included in Maintenance manuals.

In special circumstances when CAT II maintenance road can not be designed due to land restrictions, Green path may be used. In this case the Consultant must present justification with evaluation of the need of green path reinforcement and Client's and relevant National Implementing Body's approval must be obtained.

5.2. Principal schemes of Access and Maintenance roads

Access Roads are publicly used roads that shall be designed outside of railway right of way (outside fenced territory) to provide access to land plots, forest roads, households etc. Access roads can also be used to provide access to maintenance roads. In this case maximum axle load of maintenance road shall be considered during the design of connecting access road.

Maintenance roads are not open for public use and are located inside the boundary fence. It can be used only for railway maintenance purpose or for emergency services.

Public roads shall be designed according to national legislation and regulations.

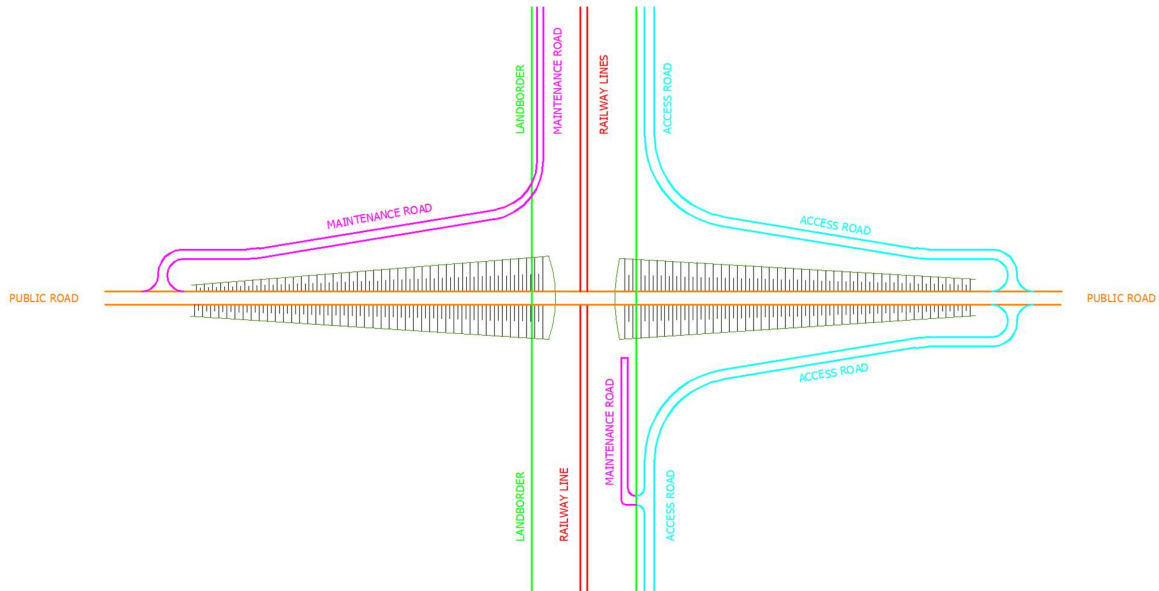

FIGURE 14 RECOMMENDED PRINCIPAL SCHEME OF ROAD CATEGORY DIVISION

Key: Land border, Maintenance road, Access road, Railway line, Public road

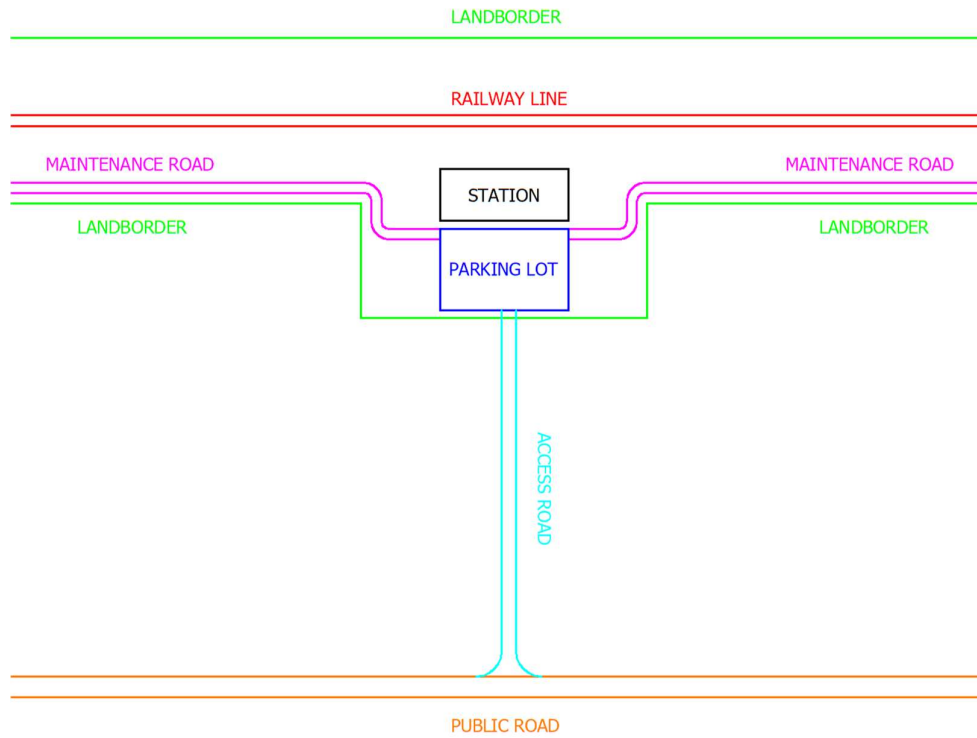

FIGURE 15 RECOMMENDED PRINCIPAL ROAD SCHEME FOR STATION AND PARKING LOT

Key: Land border, Maintenance road, Access road, Railway line, Public road

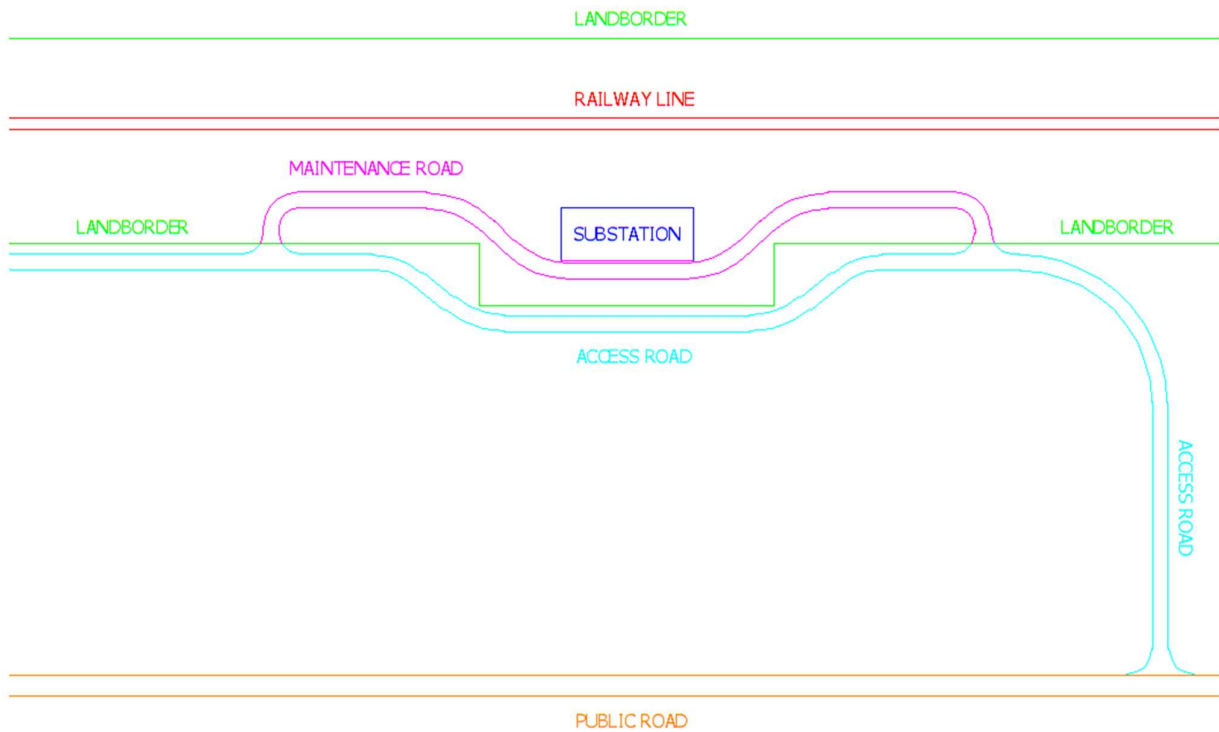

FIGURE 16 RECOMMENDED PRINCIPAL ROAD SCHEME FOR SUB-STATION

Key: Land border, Maintenance road, Access road, Railway line, Public road

In this case designed roads shall allow transporting equipment by trucks as well as handling cranes. The supposed area for operation of cranes shall be level and free from aerial cabling and other possible obstacles.

5.3. Main parameters

5.3.1. Geometrical parameters

Maintenance roads inside railway right of way shall be designed according to RBDG-DWG-065-A2 drawing. Maintenance roads shall be designed based on swept path analysis applying design vehicles defined by chapter 5.3.3. Design speed for swept path analysis shall be 30km/h. In case 30km/h is not feasible the Consultant shall agree lower Design speed with Client. Design speed of 5km/h shall be used for section from beginning of maintenance road (entrance) till section where maintenance road is designed parallel to railway.

Geometrical values for maintenance roads designing are following:

- Maximum longitudinal slope $\leq 8,0\%$
- Minimum recommended longitudinal slope $\geq 0,5\%$.
- Minimum sag R 250m (from entrance till section where maintenance road is designed parallel to railway, Min sag Radius can be reduced)
- Minimum crest R 750m (from entrance till section where maintenance road is designed parallel to railway, Min crest Radius can be reduced)
- Cross slope for unbound aggregate mixture pavement surface road 3,5% (+/-0,5%)
- Cross slope for bound material surface pavement road 2,5%
- Cross slope for shoulder 5%
- Super elevation of 5,5% (+/-0,5%) if $R \leq 150,0\text{m}$
- Minimum super elevation transition length 6m per 1%.

5.3.2. Level of Service

Newly designed access roads intersections around (<1km radius) stations, depots, terminals shall allow to flow at Level of Service (LOS) C or better according to Highway Capacity Manual 2000 (HCM). Redesigned existing intersections shall allow to flow at LOS D or better. Evaluation of LOS shall be conducted. If necessary, traffic flow modelling survey shall be carried out.

5.3.3. Design vehicle model

Design vehicle models for maintenance roads shall be chosen by Table 2: Design vehicles

Access roads design vehicle shall be chosen by national legislation and regulations. Design solutions shall provide vehicle manoeuvrability for design vehicle and shall be economically justified.

Category	Design vehicle	Parameters
I	 Truck with trailer	Total length – 18.75m Min turning radius – 12.50m
II	2-axle garbage truck 	Total length – 8.00m Min turning radius – 7.80m
Access road	-	According to national regulations and legislation

TABLE 2: DESIGN VEHICLES

5.3.4. Width of roads

The widths for different roads categories shall be determined according to forecasted annual average daily traffic and its composition. Minimum requests are defined in table below:

Category	Min total width of road	Min total width of traffic lane
I	5.50 m	3.50m
II	4.00 m	3.00m
Access road	According to national legislation and regulations or by maintenance road category	

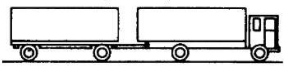
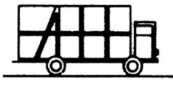
TABLE 3: WIDTH OF ROADS

Design solutions shall provide vehicle manoeuvrability, traffic safety, environmental requests and solutions shall be economically justified.

5.3.5. Horizontal and vertical clearance

Vertical and horizontal clearance shall meet national regulations and legislation. Additionally, minimum vertical clearance for overpass or tunnel shall meet Rail Baltica Design Guidelines requests if they are higher than national regulations and legislation.

5.3.6. Widening of curve

Pavement widening shall be foreseen for curvatures with $R \leq 200\text{m}$. Curvature shall be widened in whole length of the radius by the value shown in Table 4. Widening shall be designed on direction of carriageway's inside.

Horizontal curve radius	Widening
R=40m	1,2m
R=50m	0,9m
R=70m	0,8m
R=100m	0,7m
R=150m	0,4m
R=200m	0,25m

TABLE 4: CURVATURE WIDENING FOR MAINTENANCE ROADS

Designer shall apply swept path analysis to approve manoeuvrability for design vehicle.

5.3.7. Passing loops

For roads with total width $B \leq 5,5\text{m}$ additional passing loops shall be foreseen in the sight distance or at least every 500m. If the sight distance is more than 2,0km, then additional passing loops should be foreseen after every 1,0 km. Passing loop dimensions are shown on Figure 4.

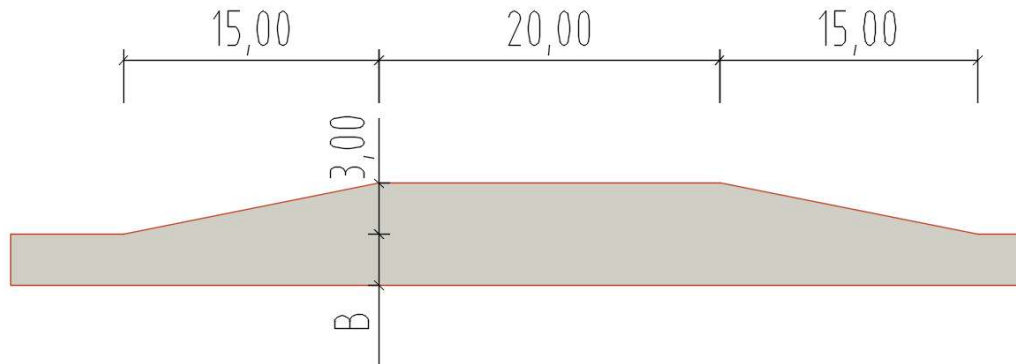

FIGURE 17 PASSING LOOP

5.3.8. Turnaround loop

For road ending with a dead end, a turnaround loop shall be foreseen. Recommended design plan layout and minimum dimensions for turnaround loop is shown on Figure 5. For cases where longest vehicle in traffic flow is foreseen truck with trailer ($L=18,75\text{m}$) necessity, plan solutions and dimensions of turnaround loop shall be approved by Client.

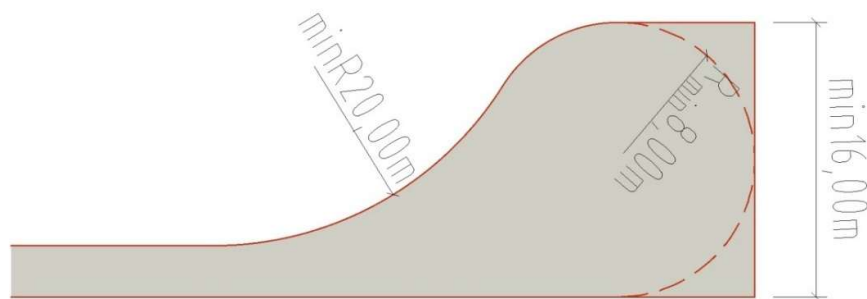

FIGURE 18 RECOMMENDED TURNAROUND LOOP

5.3.9. Exit and entrance intersections

Exit and entrance intersections shall be designed according to each national legislation. Designed intersection angle shall be 72° - 108° (80-120 gon). Maximum longitudinal gradient of adjacent road shall not exceed 2,5% for at least 25m long section, measured from side of main road carriageway edge. Principles of intersections solutions are given on Figure 6. The designer shall apply swept path analysis to approve manoeuvrability for design vehicle.

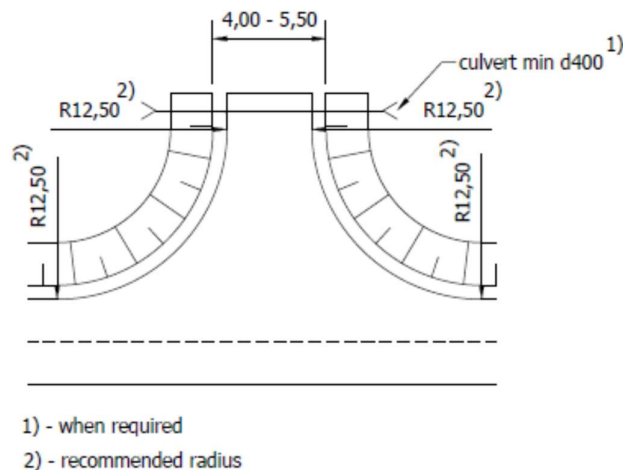

FIGURE 19 EXIT AND ENTRANCE ROAD JUNCTION FOR MAINTENANCE ROADS.

5.3.10. Road restraint systems

Road restraint systems for access roads shall be designed according to national legislation and standards (including EN 1317 "Road Restrain Systems"). For sections where, high speed railway is twinning with designed access road designer shall also observe requirements of Rail Baltica Design guidelines General requirements paragraph 7 and cross-sections RBDG-DWG-059 up to RBDG-DWG-064 depending on specific situation. Road restraint systems for maintenance roads shall be designed according to Rail Baltica Design guidelines drawing RBDG-DWG-065-A2. Technical parameters of designed safety barriers shall meet requirements of standard EN 1317. The necessity for safety barriers for maintenance roads, located inside railway right of way (inside fenced area), shall be analyzed by risk assessment from railway safety point of view.

5.4. Requirements for pavement design

Road pavement and thickness of each pavement layer shall be calculated according to national legislation and standards. Designer shall deliver detailed pavement calculation report with explanations of substantiation for used calculation parameters. For sections with low bearing capacity soils ($E_{v2} < 25$ MPa and/or $CBR < 8\%$), including peat, thixotropic soils, high plasticity clays etc., the designer shall propose at least 3 (three) different solutions. These solutions shall be fully justified with associated cost-efficiencies and appropriate calculations/analyses.

5.4.1. Basic requirements

Axel loads and Equivalent Single Axle Load (ESAL) for road types:

- Maintenance road cat. I: 11.5t/axel (18.75m long tandem axel with single tires) ESAL 100 000 – 300 000
- Maintenance road cat. II: 3,5t/axel (single axel with single tires), ESAL < 100 000
- Access roads: 11.5t/axel (18.75m long tandem axel with single tires). The ESAL shall be obtained according to traffic survey results.

Design life for the pavement is 20 years.

5.4.2. Bearing capacity

Bearing capacity on compacted surface of each layer shall be measured by static plate load test (according to DIN 18134 "Soil – Testing procedures and equipment – Plate load test"). The following strain modulus shall be met as acceptance criteria:

- Subgrade (embankment) - 45 MPa
- Subbase course (drainage layer/frost resistance layer) - 60 MPa
- Base course/surface (unbound aggregate mixture) - 120 MPa.

5.4.3. Requirements for base course

The base course shall be built using unbound aggregate mixtures. Properties for the base course aggregates shall be described based on:

- a. EN 13242 "Aggregates for unbound and hydraulically bound materials for use in civil engineering work and road construction"
- b. EN 13285 "Unbound mixtures – Specifications".

5.4.4. Requirements for frost resistance layer

The designer shall take into account the maximum permissible frost heave values described in the table below. The need for and thickness of a special pavement layers (drainage layer or frost protection layer) shall be calculated. Frost protection and drainage functions could be combined within one pavement layer (e.g. unbound mixture with low fines content and suitable permeability). The suitability of materials to fulfil these functions shall be assessed according to national regulations and/or standards.

Category of road and type of surface	Max heave value, cm
I Category	
Unbound aggregate mixture pavement	10
Surface dressing	6
Asphalt or rigid pavement	4
II Category	
Unbound aggregate mixture pavement	12
Surface dressing	8
Asphalt or rigid pavement	4

TABLE 5: MAXIMUM PERMISSIBLE FROST HEAVE PER CATEGORY

The most traditional solution to ensure frost resistant pavement is the use of course and durable aggregate. Material is considered to act as a drainage layer if the content of fines (<0.063mm particles) is $\leq 5\%$ (assessed in accordance with EN 933-1). Material properties shall be assessed according to national standards. If required, other means of tests and assessment procedures could be used to verify the draining and frost protection properties of the materials as long as adequate evidence supporting such approach is submitted for approval to Client (including calculations and cost/benefit analysis).

5.4.5. Requirements for drainage layer

The designer shall assess necessity of drainage layer and calculations to verify drainage layer thickness shall be conducted.

Drainage layers shall be designed:

- If the subgrade soil has low permeability ($K_f < 0,5$ m/24h tested according to national standards)
- If it is necessary due to hydrogeological conditions.

Proposed pavement design solution must ensure efficient drainage from the pavement. Design solutions shall ensure that the bottom of the subbase layer is at least 30cm above highest water level (incl. capillary water level).

In the case of using unbound mixture (e.g. sand, gravel) as a drainage layer, the minimum thickness shall be 30 cm. If required, other means of effective drainage solutions may be considered as long as adequate supporting evidence is submitted for approval to Client.

Materials can be considered as drainage layer if filtration coefficient is $K_f \geq 1,0$ m/24h (tested according to national standard), proportion of fine (< 0.063 mm) particles are $\leq 5\%$ of total material amount and methylene blue value ≤ 10 (test according EN 933-1 "Tests for geometrical properties of aggregates. Determination of particle size distribution. Sieving method" and EN 933-9 "Assessment of fines- Methylene blue test").

5.4.6. Requirements for subgrade

Only mineral materials that fulfils further mentioned requirements shall be used for subgrade.

Subgrade strain modulus (E_{v2}) in the upper part of the subgrade layer (≤ 1 m from the surface of the top of subgrade) shall be at least ≥ 45 MPa, or CBR $\geq 20\%$ (according to DIN 18134 "Soil – Testing procedures and equipment – Plate load test" and EN 13286-47 "Unbound and hydraulically bound mixtures - Test method for the determination of California Bearing Ratio (CBR), immediate bearing index and linear swelling"). The deformation modulus on the lower layers of subgrade (> 1 m from the surface of subgrade) shall be at least ≥ 25 MPa or CBR $\geq 8\%$. The organic content of soil shall not exceed 2% of mass in depth < 1 m of subgrade surface.

If existing soils are considered for subgrade construction, then during the design development stages the designer shall evaluate properties of soil to ensure all criteria is satisfied. If existing soils do not fulfil the requirements, then additional technical solutions shall be considered (replacing soil, construction of additional layers, usage of geosynthetic materials, stabilization of soil, etc.). The designer shall propose at least 3 (three)

different solutions and provide full justification for a cost-efficient solution supported by appropriate calculations.

5.4.7. Typical cross sections

Access roads dimensions and pavement shall be designed by national legislation, standards and regulations from the road owners. Maintenance road pavement shall be designed with unbound aggregates mixture surface, if the pavement design or Client does not require otherwise. Where bound pavement is required, the designer shall ask confirmation from the Client. Embankment height and slopes shall be designed in most cost and environmentally effective way while also considering embankment stability, land usage and susceptibility to erosion. Recommended gradients for the embankment slopes are 1:2 (50%) and ditch slopes is 1:1.5 (66.7%) respectively. Material suitability should govern the suitable slope gradient according to the short-term and long-term stability calculations.

Maintenance road with unbound aggregate mixture surface

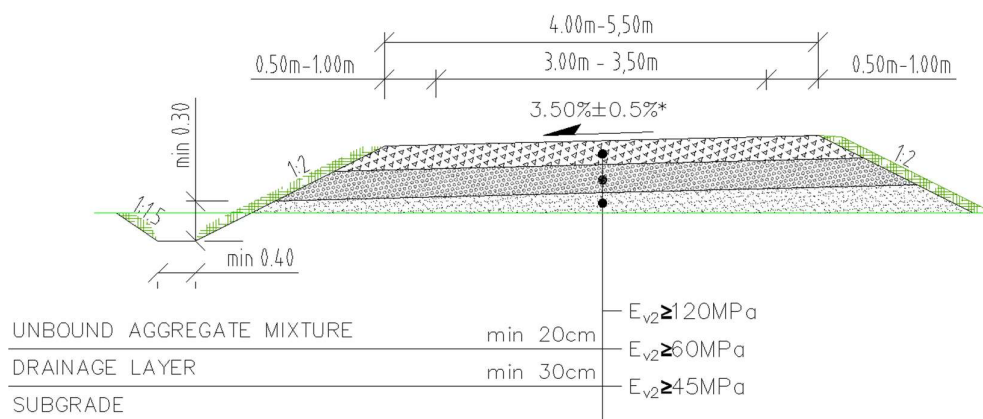

Remark:

*—in case of total road width 5.50m two sided surface cross slope could be designed.

FIGURE 20 TYPICAL MAINTENANCE ROAD CROSS SECTION WITH UNBOUND AGGREGATE MIXTURE SURFACE

Maintenance road with bound material surface

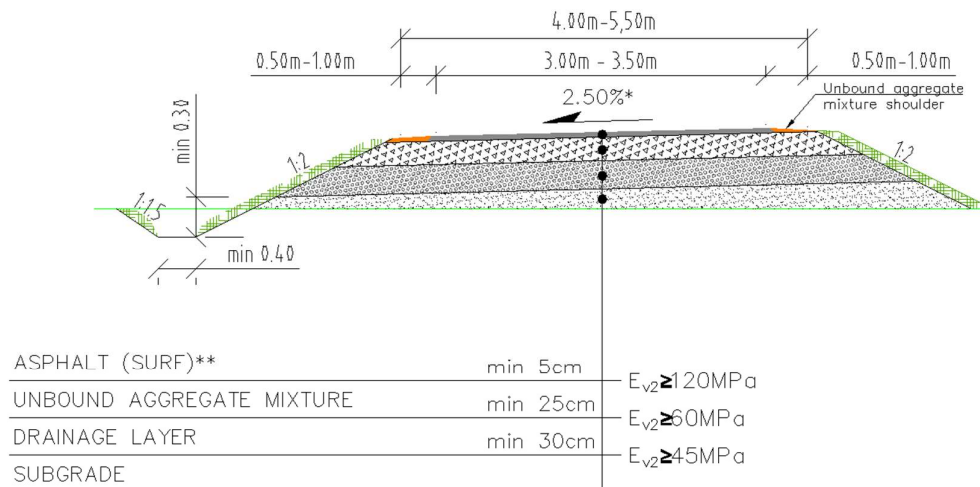

Remarks:

*-in case of total road width 5.50m two sided surface cross slope could be designed.

**-usage of chip sealing solution in specific cases is also possible. It shall be approved by Client.

FIGURE 8 TYPICAL MAINTENANCE ROAD CROSS SECTION WITH BOUND MATERIAL SURFACE

5.5. Parking areas

Parking lots are mandatory near new objects (e.g. international railway stations, local railway stations, industrial buildings, maintenance buildings, etc.).

Minimum number of parking spaces (public and for staff) across all the Rail Baltica line shall be calculated according to national legislation and regulations.

For situations where public objects are forecasted to have a high number of users, traffic flow analysis (modelling) shall be conducted. The minimum number of parking spaces may be reduced or increased according to national legislation and standards.

The parking lots in railway stations shall be adapted for disabled people according to national legislation and standards.

Parking lots technical parameters (including pavement, lightning, drainage, etc.) shall be designed according to national legislation and standards.

6. Safety and Security

6.1. Fences

Fences are an essential element for:

- Human safety,
- Traffic uniformity;
- Visual appearance, especially around engineering works.

In particular, they shall:

- Protect against accident risks (persons or animals),
- Limit malicious actions,
- Allow intervention by assistance and maintenance services;
- Allow free passage of surface water, ditches, and watercourses rebuilt by the project.

Depending upon the type of facility being protected and site particularities, using one of the categories of fences complying with the provisions in the following articles may be required.

Urban crossings shall be handled on a case by case basis.

For visual design of fences please refer to RBDG-MAN-031D and RBDG-MAN-031F.

6.1.1. Common Provisions

Fencing design and installation shall allow easy maintenance without requiring extra wide rights of way. To do this, post foundations shall not overhang, and struts shall be built exclusively within the plane of the mesh.

Metal fence components must be made of hot dip galvanized steel - thickness of zinc coating for each element has to be defined by the designer according to the appropriate atmospheric corrosivity class and other technical parameters of each fence element (e.g., regular wires of the mesh, tension wires, barbed wires, barb

wire arms, poles, gate frames) in order to ensure the necessary corrosion protection and design life. Alternatives solutions with plastic fences can be proposed for some locations as long as the protection proposed is equal or superior to equivalent to metallic fences.

Fences shall be designed to account for electromagnetic compatibility with the catenary and other electrical structures. Exposed metal conductive parts of fences shall be connected to the buried ground conductors present all along the high-speed rail line. The maximum distance between connections to ground conductors is set at 250 m.

An equipotential connection shall be made between fences and access mechanisms (doorways, gates, removable panels).

6.1.2. Standard Fences

This type of fence shall be used in agricultural areas (crops, fields) and in forested areas.

Components are:

- Stretched mesh reinforcement (800kg < tension < 1000 kg) or equivalent, 1.80 m tall above ground; In case if national EIA conditions require higher fences, national EIA conditions must be followed.
- Metal posts spaced a maximum of 5.00 m apart, with three barbed wires at 1.80 m, 1.40 m and 0.60 m above ground, able to withstand horizontal stress of 120 kg applied at 1.40 m above ground without incipient cracks or permanent deformation;
- In case if national EIA conditions require higher fences the location of the three barbed wires (mentioned above) must be adjusted in proportion to the change in the height of the fence, considering that the last barbed wire is at the top of the fence;
- In places where it is necessary the fences additionally can be topped with an anti-crossing device consisting of a barb arm with three barbed wires inclined at an angle of 45° toward the exterior;
- Corner posts, end posts, and stop posts (installed at least every 50 m) identical to those mentioned above, but equipped with struts within the plane of the mesh; these posts shall be resistant to lifting and shall not suffer top deformation greater than 15 mm under the stresses of placing the fence under tension.

6.1.3. "Sensitive Area" Fences

Sensitive areas (determined by the client and/or EIA) primarily concern:

- Areas with large animals (boars, deer, etc.) or digging animals,
- Areas around urban agglomerations,
- Around certain engineering works, etc.

"Sensitive area" fences must be constructed of standard fence elements topped with an anti-crossing device consisting of a barb arm with three barbed wires inclined at 45° toward the exterior, extending the overall height to 2.50 m.

This fence type must also include a ground anchoring mechanism (to be proposed) to prevent people or animals from passing beneath it.

In sensitive urban areas and areas with animals, suitable mechanisms shall be defined on a case by case basis through special studies and according to Design Guidelines RBDG-MAN-027.

6.1.4. Simplified Fences

This type of mechanism must be installed around retention basins in non-urban sectors. It must also be used along maintenance roads.

Simplified fences, 1.25 m tall above ground, may be constructed of mesh reinforcement or four barbed wires on treated wood (fungicide) or metal posts hammered into the ground or equivalent.

For basins, a padlocked access mechanism (minimum effective width = 3 m) shall be planned.

6.2. Alternatives systems

Alternative systems are possible for some area with no local access provided the approval of the system by the NSA. Any alternative system shall ensure following functions:

- Protect against accident risks (persons or animals),
- Limit malicious actions.

6.3. Access Points

The positions of road and pedestrian access points for the high-speed rail line track inside fences shall be identified for listing on general line maintenance documents and on emergency plans that will be made available to the services concerned.

An equipotential connection shall be provided for all access points.

6.3.1. Portals

The portals providing road access adjacent to boundary fences and "sensitive areas" shall comply with following requirements:

- Height = 1.80 m;
- Minimum passage width = 4.00 m with 2.80 m and 1.20 m leaves;
- Tubular framing with mesh (standard areas) or barred (sensitive areas) panels;
- 50 cm tall studs with barbed wire aligned with those on the fences in sensitive areas;
- Provisions to block leaves and maintain them in the open position;
- Double barrelled safety lock (maintenance, emergency);
- Potential provision for closure using a padlock and chain.
- Support posts independent of the fences; they must be sealed inside concrete pads and linked by reinforced concrete sill able to bear the access road traffic capacity;
- Clamping device for the leaves on the posts preventing their opening by removal of hinges.

6.3.2. Safety Gates

Safety gates for "pedestrian" access shall be 1.80 m tall and have a minimum passage width of 1.20 m. They shall adhere to properties identical to those for portals, except for road part.

6.3.3. Movable Passages

Exceptionally, "fence opening" passages may be planned in place of doorways for access to specific low-traffic areas (planted areas, for example).

Panels using standard chain link fencing shall have 4.00 m openings and be equipped with a padlocked closure (fence posts and levers).

6.4. Fences on bridges and structures

6.4.1. Types of fences

Connecting fences are for embankment areas close to existing roads. For aesthetic and economic reasons, using standard devices is recommended. For significant slopes, it is permitted to install a more "flexible" fence constructed of standard fence posts, spaced a maximum of 3.00 m apart. Posts shall support ordinary twisted straps, banded over 5 rows of stretched wires, and attached to all supports. Barbed wire may also be used as for standard fences.

6.4.2. Installing Fences in the Vicinity of Structures

In particular, adjacent to engineering works, fences shall protect the facilities against vandalism, and prevent people from coming too close.

These objectives require enclosing all infrastructure facilities in the protected area, especially:

- Vehicle and load fall detectors, especially for elements on the ground built on concrete posts and installed on branch lines (typically perpendicular) from the road bridge slabs at the end of the track overhang;
- Areas with overhanging electric power supply feeders (anchored to the road bridge supports) and their electrical protection distance. These areas shall not be outside fences.

6.4.2.1. *Road bridges with approach spans*

Provisions for connecting fences to structures

Fences shall not be connected directly to the ends of railings, as crossing the railing would give access to the right of way from the bridge.

To prevent potential intrusions, it is possible to raise the railing over the entire length of the footing with an anti-vandalism screen or with vertical catenary protections that are normally installed for track overhangs.

In general, this solution is not used for reasons of cost and visual impact.

The distance between any point on a structure accessible to the public and its vertical projection on the premises shall be at least equal to the height of the fence. An effective solution is to construct the fence connection straight above the guideway beam. Protection of the support apparatus would be ensured from this point by a triangular return aligned with the edge of the guideway beam.

Provisions for installing fences around approach embankments

In all cases, installing fences in these areas shall create sufficient space to allow the installation of any potential vehicle and load fall detectors on the ground.

In general, this space shall be at the end of the structure's footing.

6.4.2.2. Case of frame type road bridges with support walls alongside the tracks

Fences must follow the support wall with a low profile to allow the potential installation of vehicle and load fall sensors. They must be connected to the required catenary protection screens on the top of the walls near the railing on the structure. Direct proximity with the road must be avoided to limit deterioration risks.

6.4.2.3. Underpasses

In principle, fences must be connected to the ends of the support walls. If their height is insufficient at this point, the gap can be filled with a custom made triangular connection. This connection must be installed directly above the exterior screed on the wall to remove any possibility of support for climbing.

To avoid the need to construct triangular connections on demand, positioning standard sized rigid fence elements in front of the walls may be allowed.

6.5. Fences for Electric Power Supply Substations

These fences for the facilities with enclosures (substations, autotransformer) may be metal (welded reinforced mesh) or reinforced concrete and shall meet the special specifications listed below.

6.5.1. Purpose of a Substation or Pylon Fence

Fences around substations or autotransformer pylons shall be designed to delimit an area containing electrical facilities. Thus, for this reason they shall isolate and warn the public of electrical hazards.

Fences shall be able to resist the natural mechanical loads due to snow and wind as well as atmospheric chemical stresses.

The designer of the substation shall perform a risk analysis identifying if risks of malicious intrusion exist and then the specific provisions shall be proposed to the Client.

6.5.2. Fence Types

Fences shall have a minimum height above finished ground level (gravel or pavement) of 2.60 m, not including barb arms.

Different fences are possible and the application of each type of fence depend on the risk analysis.

6.5.2.1. *Chain link fences without barb arms*

The size of the horizontal links must not be greater than 40 mm.

The base must be constructed of solid components 50 cm tall buried 25 cm below finished ground level.

Mesh to a height of 2.50 m must cover 15 cm of the base components. It must be installed on support posts and tightener tubes (at least 4) and must be attached using attachments.

Support posts must be spaced 2.00 m apart and may not have braces outside the fence plane. Their profile must provide resistance to service and breaking mechanical stresses.

Connections between mesh rolls must be made adjacent to supports; clamping must have a width identical to that of the posts and at must be least 5 mm thick.

6.5.2.2. *Chain link fences with barb arms*

These fences can be topped, upon client request, with a 0.80 m barb arm inclined at an angle of 45° toward the exterior. This additional device must include three 2.7 mm diameter galvanized steel barbed wires.

6.5.2.3. *Concrete fences without barb arms.*

This type of fence shall be constructed of posts and reinforced concrete sheet piles.

The base shall be constructed of 50 cm tall reinforced concrete sheet piles, installed at an elevation of - 0.40 m in relation to finished ground level.

6.5.2.4. *Concrete fences with barb arms*

These fences shall be constructed with the same components as concrete fences without barb arms, but topped with a 0.80 m barb arm inclined at an angle of 45° toward the exterior. This additional device shall include three 2.7 mm diameter galvanized steel barbed wires.

6.5.3. Doors and Safety Gates

Doors and safety gates must be constructed of galvanized tubular frames with panels attached with galvanized bolts. The assembly shall be constructed so that dismantling is impossible from the exterior of the enclosed facilities.

The equipment must include a chock and a device to maintain each leaf in the open position. The leaves, which must open a minimum of 120°, must be equipped with devices to prevent opening by removal of the hinges.

Doors and safety gates must have solid panels on the lower part up to a minimum height of 0.50 m, and bars on the upper part.

6.5.4. Grounding

Grounding cables for the substation shall never be in direct contact with fence posts or mesh. Grounding cable feeds shall be located within facility enclosures.

Metal fence (with or without barb arms) components shall be grounded using a bare copper wire buried underneath the mesh at a depth of 50 cm beneath finished ground level.

Each length of mesh shall be grounded; the distance between two ground cable feeds must be less than 24 m.

The exposed conductive parts of door and safety gate posts shall be connected with a copper wire.

6.6. Protective Devices on Road Bridges

Measures shall be taken to prevent the accidental penetration of road vehicles or their loads into HSR rights of way.

All road bridges crossing high-speed rail lines shall undergo a risk analysis to define the provisions that will be implemented with the structure and its surrounding areas to prevent the intrusion of road vehicles.

This risk analysis shall consider the requirements from UIC 777-1 R "Measures to prevent impacts by road vehicles against rail bridges and to prevent the penetration of vehicles onto the track" and the average traffic 15 years after commissioning the line.

The results of the risk analysis and the selection of protective devices shall be submitted for the client's approval.

6.6.1. Devices to Prevent the Intrusion of Road Vehicles

Protection against road vehicles and their loads falling shall be separate from protection against electrical hazards.

Retainers on structures shall be design according to Spanish standard OC 35/2014 requirements. Containment level shall be selected as per Table 6 requirements. Where it is legally binding, country's local requirements shall be followed if more stringent requirements are in force.

Daily heavy vehicle traffic	Containment level
≥ 2000	H4b
< 2000	H3

TABLE 6: RETAINER CONTAINMENT LEVEL SELECTION ON ROAD BRIDGES

Retainers shall also be approved and have passed acceptance tests corresponding to the required retention level in application of Standards EN 1317-1, EN 1317-2, EN 1317-4 and EN 1317-5.

On arteries with significant heavy truck traffic (heavy vehicle composition >30% from average daily vehicle traffic) road retainers shall be accompanied by a 3-meter-tall load discharge prevention screen.

6.6.2. Vehicle Intrusion Detectors for Intrusion into Rights of Way

Structures shall be equipped with a detection system acting on the railway signalling if road vehicles intrude into the railroad right of way.

Vehicle intrusion detectors shall be designed according to Spanish legal act BOE-A-2020-13115 requirements.

7. Constraints for highway parallel to high speed line

7.1.1. Twinning with high traffic routes

The anti-penetration protections to be implemented along the high-speed line in the case of twinning with major traffic roads (motorways, national roads, major departmental roads) is defined according to the distance between the limit of the railway installations and the limit of the roadway (identified as "L1" distance in the cross sections).

The above limits are defined as follows:

- Limits of the roadway:
 - Outer edge of the Emergency Stopping Lane
 - Outer edge of the Outer Shoulder

- Limits of the railway installations:
 - Outer edge of the railway embankment (external generator of the drainage system like ditch, outer edge of cut or the toe of the fill, outer edge of a noise barrier).

Several cases shall be applied depending on the value of the distance L1 and the difference in elevation between the high-speed line embankment and the road embankment. These cases are summarized below for application.

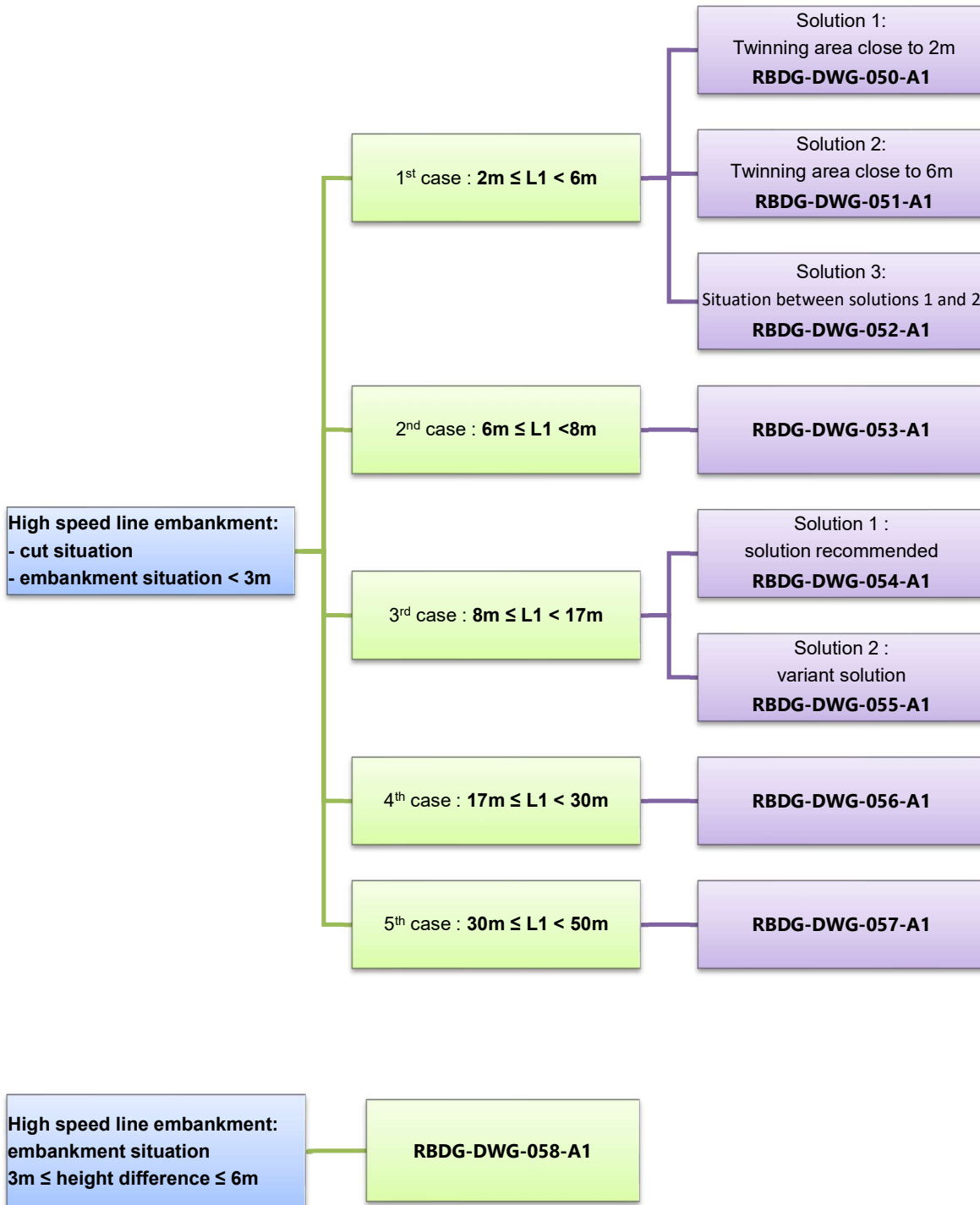

7.1.2. Twinning with secondary roads

In the case of twinning with secondary roads with low traffic, in particular maintenance roads built outside the rights-of-way to establish access to the high-speed line embankment, to open up isolated plots or resettle a minor roadway towards a bridge crossing the road HSR, safety devices shall be provided when the high-speed line embankment is:

- in embankment of a height less than or equal to 1m from the secondary network,
- in cut whatever the depth is.

The safety device to be used is a merlon whose minimum height from the roadway is 1 m, associated with a ditch. The characteristics of the merlon and the ditch are shown on the standard cross - sections presented in annex.

Specific case:

- In the case of a single-lane lateral lane, in order not to double the drainage system, a merlon without ditch will be implemented with a height of 1.5m from the roadway level.
- If there is insufficient space to install a merlon, the installation of a metal or concrete retaining device, suitable according to the traffic and speed limit of the roadway, will be considered.

Different cases occur according to the available space and the altimetric difference between the high-speed line **embankment** and the road **embankment** (refer to typical cross sections):

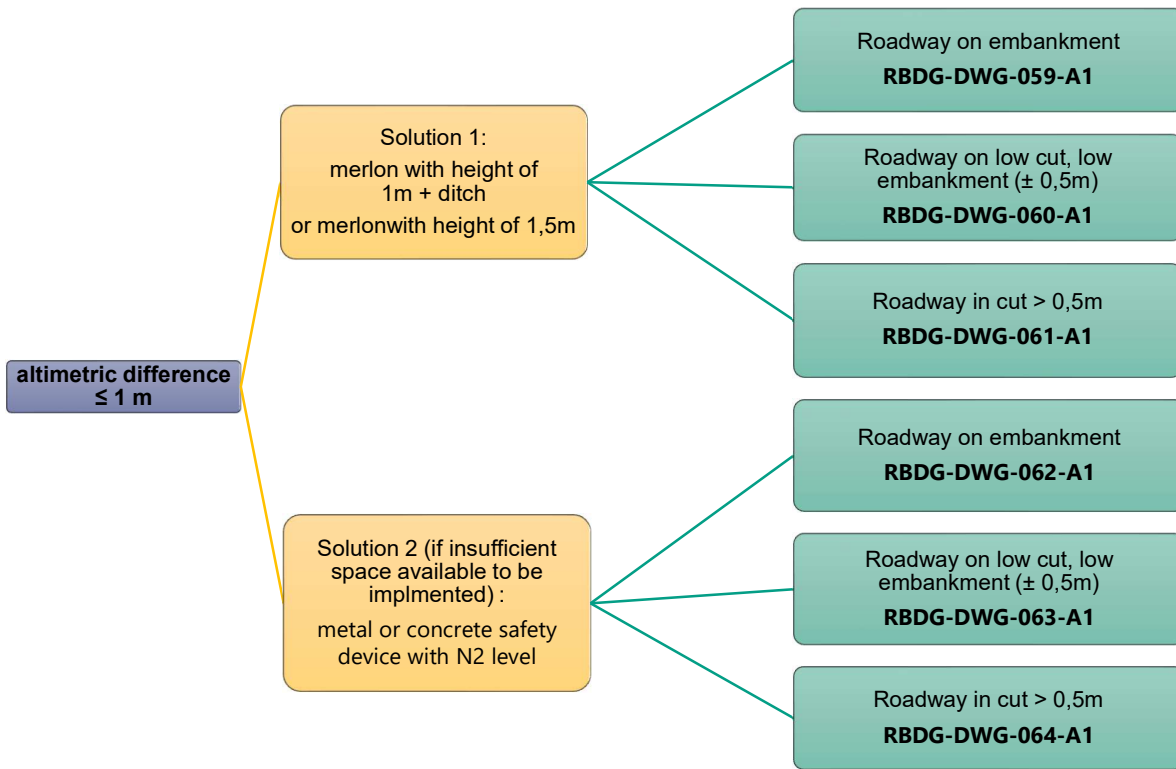

8. Environmental conditions for systems

All System shall be designed and constructed in compliance with EN 50125-2 and EN 50125-3. Parameters stated in these standards and below also apply to non-electric components of the railway systems, except if other, system specific requirements are more stringent.

8.1. Atmospheric pressure / Altitude

All system shall be A2 defined as per §4.2 of EN 50125-2 and §4.2.1 of EN 50125-3.

The Signalling and Telecommunications System placed in tunnels shall withstand typical pressure variation (+/-5kPa) defined in §4.2.2 of EN 50125-3.

8.2. Temperature

All system shall be constructed to withstand temperatures equivalent Class T2 as defined in EN 50125-3, chapter 4.3.

8.3. Humidity

All system shall be constructed to withstand humidity according to class T2 in EN 50125-3, chapter 4.4.

8.4. Wind

All system shall be constructed to withstand wind according to EN 50125-3, chapter 4.5 and EN 50125-2, chapter 4.4.1 with a maximum wind flow velocity of $v_{10} = 24m/s$ (W1).

The wind velocity W1 is defined in accordance with requirements from Eurocode of the 3 countries.

8.5. Surrounding air

All system shall be constructed to withstand wind velocity according to class SW 1 (low – 0.6m/s) in EN 50125-2, chapter 4.4.

8.6. Rain

All system shall be constructed to withstand a rain intensity of 6mm/minute as stated in EN50125-2, chapter 4.5 and EN50125-3, chapter 4.6.

Signalling and Telecommunication systems shall be in line with international protection classes according to IEC 60529.

8.7. Snow, ice and hail.

All system shall be constructed to fulfil requirements as stated in EN 50125-2, chapter 4.6 and EN 50125-3, chapter 4.7. All system shall be designed for the effect of hail. The diameter of the hail stones shall be taken as 15mm.

The Signalling and Telecommunications System shall be constructed to withstand normal ice lumps that fall off moving rolling stock and fulfil requirements stated in EN 50125-3, chapter 4.8.

The Catenary System shall be designed taking into account snow and ice load to a temperature up to +5°C. The Catenary System shall be designed for an ice load of class I3 (heavy 15N/m) on conductors.

8.8. Solar radiation

All system shall be constructed to withstand solar radiation as stated in EN 50125-3, chapter 4.9, with a maximum radiation effect from the sun of 1120 W/m² and EN 50125-3, chapter 4.8 (category R2).

8.9. Lightning

All system shall be designed for the effects of lightning according to the Standards EN50124-1 and EN50124-2.

8.10. Pollution

All system shall be designed considering the low pollution levels 4C1, 4B1 and 4S1 if the EIA is not stating otherwise.

Where located in tunnels such as defined in the Standard EN50125-2, all system shall be designed for high pollution levels 4C3, 4B1 and 4S3.

Where located in bridges crossing highway or train network, all system shall be designed for high pollution levels 4C3, 4B1 and 4S3.

For coastal area, all system shall be designed for high pollution levels 4C3, 4B1 and 4S3.

Signalling and Telecommunication systems shall be in line with international protection classes according to IEC 60529.

8.11. Vibration and shocks

Vibrations and shocks are defined as per chapters 4.13.1, 14.13.2 and appendix C of EN 50125-3.

8.12. Fire protection

The Catenary System shall be designed for fire protection according to the Standard EN50125-2.

The Signalling and Telecommunications Systems shall be protected with a gaseous fire suppression system based on e.g. inert gas as stated in EN 12094.

All products shall be in compliance with Regulation (EU) 2016/364 of 1 July 2015 on the classification of the reaction to fire performance of construction products and the related Construction Product Regulation (CPR).

	Euroclass	Classification criteria	Additional criteria	AVCP system (Assessment and Verification of Consistency of Performance)
 Severity	<i>"Non combustible"</i> (e.g. mineral insulated)			
	A _{ca}	EN ISO 1716 Gross heat of combustion		"1+", including: <ul style="list-style-type: none"> initial type-testing and continuous surveillance, Audit & testing of samples by 3rd party certification body Factory production control by manufacturer
	B1 _{ca}	EN 50399 Heat release Flame spread EN 60332-1-2 Flame propagation	Smoke production (s1a, s1b, s2, s3) EN50399/EN61034-2	
	B2 _{ca}		Acidity (a1, a2, a3) EN 50267-2-3	
	C _{ca}		Flaming droplets (d0, d1, d2) EN 50399	
	<i>"Low-Fire-Hazard" cables</i> (various levels)			
	D _{ca}			"3", including <ul style="list-style-type: none"> initial type-testing by 3rd party laboratory
<i>"Standard cables"</i>				
E _{ca}	EN 60332-1-2 Flame propagation		factory production control by manufacturer	
<i>No performance determined</i>				
F _{ca}	EN 60332-1-2 Flame propagation		"4" : initial type-testing and factory production control by manufacturer	

A risk assessment shall be carried out in the next design phases in order to establish fire protection measures. Passive fire protection measures shall be provided where the risk of fire spread is identified as too high.

Passive measures shall be adopted in preference to the provision of active systems.

The following rules shall be at least applicable:

- On the base of the fire risk assessment the designers in the next stage will define the fire class cable for each kind of use with regard to severity fire risk. The following criteria shall be taking into account:
 - B2ca s1a d1 a1 for areas with very high fire risks
 - Cca s1 d1 a1 for areas with high fire risks
 - Dca for areas with medium or high fire risks
 - Eca for areas with medium or low fire risks.
- All service penetrations including cable ducts and routes shall be fire sealed
- Electrical equipment shall present no fire risk for neighbouring materials
- Toxic gases during combustion shall be avoided by adapted equipment;

- The technical rooms, which are railway operation critical, shall be equipped by a fire safety system with an OCC's report.
- Active fire suppression systems shall only be included in the design where it has not been possible to reduce the fire risk to an acceptable level by other means.

9. Corrosion and exposure class

9.1. Corrosion class for steel parts

The steel parts and structures shall be designed considering atmospheric corrosion class C4 according to EN ISO9223. Higher requirements might be requirement for specific location as per environmental conditions. Designer shall justify efficiency and sufficiency of the proposed solutions regarding protection measures for steel structures.

9.2. Exposure class for concrete parts

Concrete parts/Structures shall be designed considering exposure classes according to EN 206. Choice of the exposure class is dependent on the application and environmental conditions. Design shall justify the exposure class chosen as per environmental conditions and type of structure. In case of concrete platform structure designer shall consider necessary protection measures regarding the use of de-icing agents.

Appropriate requirements for concrete must be provided depending on exposure class. The recommended exposure class for surfaces protected by waterproofing is XC3. The recommended classes for surfaces directly affected by de-icing salts are XD3 and XF4.

10. Cableways

This chapter defines the minimum requirements on cableways on open line sections, in stations, in stopping points and in Systems Equipment Locations. Where necessary, additional cable ducts might be required based on detailed system design.

Definitions:

- Cableway: cable guiding and supporting system intended for cable installation including different cable path system elements: ducts, cable channels, multiducts and manholes.
- Duct: HDPE or PP pipe used to protect all types of cables, laid directly under the ground or in cable channels.
- Cable channel: plastic or concrete U-shaped prefabricated element with cover, used for protection of ducts and cables. Cable channels are installed on surface along the track, on the earthworks or on structures.
- Multiduct: specific duct for optical cables, aggregating several microducts of inferior diameter.
- Manhole: prefabricated modular concrete chamber for pulling, connecting and dispatching of ducts, cables and cable channels.

Detailed technical requirements of cableway elements such as multi-ducts, cable ducts, manholes and cable channels are defined in annex I "Technical specifications for the supply of multi-ducts, cable ducts, manholes and cable channels for construction of Rail Baltica railway line".

10.1. Cableways on open line

Along the entire main line there shall be designed 3 multiducts on each side of the line (please refer to the drawing below) with maximum Outer Diameter (OD) of 70mm and not less than 7 x 16/12mm microducts for installation of fibre optic cables including:

- 1) one multiduct on each side of the line for railway systems backbone network needs
- 2) one multiduct on each side of the line for local railway systems connections
- 3) one multiduct on each side of the line for cross-border digital infrastructure

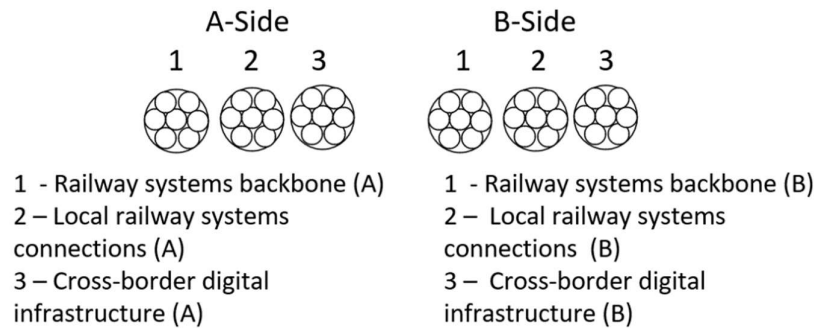

1. CABLEWAYS LAYOUT ON OPEN LINE

Multiducts on open line shall be directly buried or installed in cable ducts and cable channels when located in earthworks.

Distance between manholes shall not be more than 1 km and at locations defined in requirements of the Section 10.4 Concept solutions.

Multiduct connection to manholes shall be airtight.

Cableways for fibre optic cables shall be designed to provide two geo-redundant routes for cable connection to Systems Equipment Locations.

Multiducts shall be designed with minimum possible multiduct connections number between Systems Equipment Location areas with the minimal recommended length of not less than 1km and with maximum length of 1.2km between two open multiduct ends in manholes on open line and in station area.

Cableways along railway track shall be designed avoiding horizontal and vertical turns and elevations as much as possible.

10.2. Cableways in Stations, Stopping points and Systems Equipment Locations

Through stations, stopping points and Systems Equipment Locations shall be designed:

1. Main multiducts – in continuity with open line
 - one multiduct on each side of the line for railway systems backbone network needs
 - one multiduct on each side of the line for local railway systems connections
 - one multiduct on each side of the line for cross-border digital infrastructure
2. Communication, LV /MV voltage and local railway systems:
 - 3 ducts on each side of the line with OD of 110 mm

- Maximum distance between manholes 200 m
- Recommended minimum distance between manholes 50 m

In case if additional cables for connection of trackside equipment, return current / negative feeder for traction subsystem, etc. shall be installed, these shall be laid in additional cable channels or ducts.

10.3. General requirements

Designed cableways shall provide at least 25% spare capacity in each duct separately for future needs. Designer shall design cableways in addition to described above in chapters 10.1 and 10.2 in case if these will be required for provision of spare capacity.

Designed duct compression strength parameters shall be at least 750N and 1250N for ducts used for undertrack crossing. Duct compression force tolerance shall be selected according to IEC 61386-1. Designer shall provide static load calculations for each type of undertrack crossing solution.

10.3.1. Distance requirements

10.3.1.1. Cable ducts

HV/MV (with voltage higher than 1kV) and LV or copper signalling cables shall be installed in different ducts.

Cable ducts shall be designed at a horizontal distance more than 30 cm from catenary mast foundations, 1m from drainage manhole and more than 3,1 meters from railway track axis. Exceptional cable duct distance value of 2,8m from track axis and 0,5m from drainage manhole may be applied in case of limited installation space condition for cable ducts, which do not allow to implement the nominal distance of 3,1m.

Cable ducts shall be laid at the minimum depth of 0,8m from soil surface (measured from the top edge of the highest duct). Exceptional cable duct depth values may be applied in case of underground structure elements, e.g. culverts, which do not allow to implement the nominal depth of 0,8m:

- 0,5m, with a marking on site;
- 0,3m, with ducts covered by poured concrete or plate and with a marking on site.

The above-mentioned exceptional values for depth shall be coordinated and approved by RB Rail AS and are applicable only if:

- The edge of the closest cable duct is located at the distance of 3,1 m from the nearest track axis;
- On the length of maximum 10 m;

otherwise cable ducts shall be installed in surface cable channels.

Signal wire shall be designed to be installed together with cable ducts for location purposes during railway operation.

Cable ducts crossing under the tracks shall be designed at minimum depth of 1,2m below the sleeper, measured between the lower edge of the lowest sleeper and the upper edge of cable ducts.

10.3.1.2. *Cable channels*

Cable channels shall be located only in pedestrian walking areas without possibility of traffic. Designed surface load shall be not less than 10kN/m².

Cable channel and covers shall be designed to avoid any horizontal movement of cover, due to its usage as walkway.

All cable channel covers shall be designed with non slippery surface.

A minimum distance of 10cm between MV (with voltage higher than 1kV) and LV or copper signalling cables shall be provided with a separator, and in compliance with EMC standards.

If cable channels aimed for cable transition from manholes to track side equipment are designed along the track, it is recommended to locate them in the center of the maintenance path and system space, except for cable channels located in structures.

For duct transition from manhole to cable channel on culverts and bridges, the transition element of the cable channel shall be designed in the centre of the manhole.

In any case, cable channels shall be designed at distance not less than 3,1m meters from railway track axis.

Where cable channels are designed to be installed in the subballast layer:

- The minimum thickness of subballast layer under the cable channels shall be 30 cm. This could be achieved by increasing the thickness of the subballast layer at the location of cable channels. In this case, the subballast layer with increased thickness shall be extended to the side of the embankment.
- Additionally, track permeability could be maintained by using special layer under the cable channels. This layer shall be made with coarse aggregate, with $d \geq 8$ mm or using geosynthetics with draining function to allow rapid permeability under the cable channel. In case coarse aggregate layer is considered, the minimum thickness shall be 10 cm. In case the geosynthetics are considered, the layer thickness shall be selected depending on the product.
- The detailed properties of the coarse aggregate or geosynthetic shall be coordinated and approved by RB Rail AS and described in the material Technical Specifications.
- Designer shall specify temperature requirements for HDPE ducts to be installed in the cable channel to prevent warping due to the different temperature behaviour of HDPE pipes and cables.

10.3.1.3. Manholes

Manholes shall be designed at a distance more than 5m from catenary mast foundations and more than 3,1 meters from railway track axis. Exceptional cable manhole distance value of 2,9m may be applied in case of limited installation space condition for manhole, which do not allow to implement the nominal distance of 3,1m. If the distance is less than 5m from catenary pole foundation, designer shall provide calculations of static loads.

Manholes shall be located only in pedestrian walking areas without possibility of traffic. Manhole cover load class shall be not less than B125, according EN 124:2015.

All manhole covers shall have protection against unauthorized access.

All manhole covers shall be designed with non slippery surface.

Manhole covers shall be designed in a way that they cannot fall into the manhole and harm personnel or equipment.

Ladders for personnel access and shelves for cable organization purposes shall be designed inside the manhole.

Manhole and cable channel connection elements shall be designed at a distance more than 3,1m meters from railway track axis.

Described below minimal cableway system element horizontal distances shall be applied.

Element*	Element width, m	Distance from track axis, m	Distance from drainage manhole, m	Distance from catenary pole foundation, m	Distance from track axis to element axis, m
Cable ducts type (CD1, CD2, CD3)	0,39	3,1	1	0,3	3,3
Cable channel Size 1 (CC 1)	0,4	3,2	Located in the centre of maintenance and systems path		
Cable channel Size 2 (CC 2)	0,5		Located in the centre of connected manhole**		
Cable channel Size 3 (CC 3)	0,8				
Cable manhole Type IV and Type V	1,0	3,1	5	5	3,6
Cable manhole Type VII	1,4	3,1	5	5	3,8
Manhole and cable channel connection elements	0,84	3,1	-	-	3,5

* all referred element types are described in Section 10.4.1.

** used only on culverts and bridges.

10.3.2. Protection from ground and rainwater

Cableways elements shall be protected against rain and ground water overflow, which shall include:

- All manholes shall have rainwater drainage or connection to drainage system;

- If according to the results of the geotechnical survey, hydrology study and modeling HWL above bottom of manhole level has been detected in the area of the manhole installation and water may accumulate in the cable manholes, the civil design shall provide solutions.

10.4. Conceptual solutions

Conceptual cableway solutions shall be applied for all railway sections as described below. In exceptional cases such as presence of other infrastructure or spatial constraints which limit implementation of the described below concept cableway solutions, any deviations shall be coordinated with RB Rail AS.

In exceptional cases (see RBDG-MAN-012, Chapter 3) when cable ducts shall be designed in already built or designed sections as well in cases of urban constraints, parallel railway infrastructure and other limited space conditions, when the cableway requirements of Design Guidelines cannot be met, an alternative solution that ensures all originally required cableway functionality is allowed.

10.4.1. Cableways elements

Described below conceptual solutions shall be applied for cableways elements:

10.4.1.1. *Cable ducts*

Cable duct capacities shall be designed, according specific needs of the systems on every location, based of the following configuration:

- Cable Duct type 1 (CD 1) consists of 3 multiducts with an outer diameter (OD) not more than 70 mm and with not less than 7 microducts – typical arrangement of open line;
- Cable Duct type 2 (CD 2) consists of 3 multiducts with an OD not more than 70 mm with not less than 7 microducts, which are inserted in 3 ducts with an OD of 110 mm - typical arrangement for culvert and bridges;
- Cable Duct type 3 (CD 3) consists of 3 multiducts with an OD not more than 70 mm with not less than 7 microducts, which are inserted in 3 ducts with an OD of 110 mm, plus 3 ducts with an OD of 110 mm - typical arrangement for stations, in Stopping points and in Systems Equipment Locations.

It is preferable to route cable ducts alongside of siding tracks rather than main track due maintenance convenience.

10.4.1.2. *Cable channels*

Channel capacities shall be designed, according specific needs of the systems on every location, based of the following configuration:

- Cable Channel Size 1 (CC 1) consists of a precast cable channel with integrated cover with outer dimensions of 400 x 275mm and internal dimensions not less than 240 x 155mm on turnout area, Systems Equipment Locations area and ecoducts;
- Cable Channel Size 2 (CC 2) consists of a precast cable channel with top laid cover with outer dimensions of 500 x 270mm and internal dimensions not less than 370 x 155mm on culverts and bridges on open line;
- Cable Channel Size 3 (CC 3) consists of a precast cable channel with top laid cover with external dimensions of 800 x 270mm and internal dimensions not less than 700 x 155mm on culverts and bridges on station area.

HDPE pipes in the cable channel for additional protection of backbone cables shall be designed only at locations when underground duct could not be designed (e.g. on bridges and culverts).

10.4.1.3. *Cable duct crossings under the railway track:*

Under railway track crossings capacities shall be designed, according specific needs of the systems on every location, based of the following configuration:

- 5 ducts with OD of 110mm
 - Not less than every 1km;
 - At least on one side of the ecoduct and railway bridge ;
 - At least on one side of the culvert (only in exceptional case, when cable ducts cannot be designed according to exceptional values defined in Section 10.3.1.1 as described in Fig 8 and Fig 14);
 - At both sides of the railway bridge (for bridges longer than 50m) and additional 5 ducts with OD of 75mm in the middle for railway bridge with length more than 500m;
 - At Stopping point: at 100m distance from each side of the platform edge;
- 10 cable ducts with OD of 110mm
 - Not less than every 400m in area of siding tracks in a station;
 - At both sides of the turnout area, but not closer than 2m to the turnout: measuring from the turnout toes or the shunting limit;
 - At station area: at one side of railway bridge (for bridges shorter than 50m), at both sides of the railway bridges (for bridges longer than 50m) and additional 5 ducts of 75mm in the middle for railway bridge with length more than 500m;

- At station area: at one side of culverts (only in exceptional case, when cable ducts cannot be designed according to exceptional values defined in Section 10.3.1.1 as described in Fig 8 and Fig 14);
- At both sides of Systems Equipment Locations;
- 15 HDPE cable ducts with OD of 110mm in the middle of platform area;

10.4.1.4. *Manholes*

Concrete prefabricated modular manholes shall be designed:

- At Systems Equipment Locations – as described in Fig 5;
- On Open line – every 1km and at each road overpass as described in Fig 6;
- At ecoducts – on one side of the structure as described in Fig 7;
- At culvert – only in exceptional case, when cable ducts cannot be designed according to exceptional values defined in Section 10.3.1.1 as described in Fig 8 and Fig 14;
- As railway bridges – as described in Fig 9 and Fig 15;
- At stations as described in Fig 10 and Fig 11;
- At stopping point as described in Fig 12;

Designer shall use the following manhole types, depending on the location and needs:

- Manholes type IV with single cover, inner dimensions of 90x80cm and outer dimensions of 110x100cm. Manholes type IV shall be designed in cases when there are no undertrack crossings or the number of ducts for undertrack crossing is 5 or less;
- Manholes type V with double cover, inner dimensions of 140x80cm and outer dimensions of 160x100cm. Manholes type V shall be designed in cases when the number of ducts for undertrack crossing is 10 or 15;
- Manholes type VII with double cover, inner dimensions of 140x120cm and outer dimensions of 165x140cm. Manholes type VII shall be designed in cases when the number of ducts for undertrack crossing is 15 and this undertrack crossing (or single manhole) is designed for entrance in equipment rooms at station, stopping point and Systems Equipment Location.

On open line sections with at least 3 km distance between two neighbouring System Equipment Locations, dimensions of the manhole located in the middle of the section (but not less than each 2 km) shall be increased to Manhole type VII in order to provide sufficient space for placing cable reserve loops.

10.4.1.5. Manhole and cable channel connection elements

The connection elements shall have the following dimensions:

- Precasted element with minimal inside dimensions of 40cm height, 40cm length (parallel to the track) and 70cm width (perpendicular to the track) for cable transition from manhole to precasted cable channel CC 1;
- Precasted element with minimal inside dimensions of 120cm height, 120cm length (parallel to the track) and 70cm width (perpendicular to the track) for cable duct and cable transition from manhole to precasted cable channel CC 2 and CC 3;

Designer shall increase dimensions of the cable channel and the manhole connection element shall be adjusted if it is required to meet bending radius.

10.4.1.6. Cableways in platforms

Connections from main cableways in platforms to the equipment and objects located on platforms or in the track, shall be implemented by means of cable channels integrated in platform surface design or ducts buried in platform structure that are connected to platform manholes.

10.4.2. Minimum cableways system configurations

Described below minimum cableways system configurations and capacities shall be applied.

Railway section	Location	
	Open line	Station area
Along track	CD 1	CD 3
Systems Equipment Locations	CD 3 + CC 1	
Bridges	CD 2 in CC 2	CD 3 in CC 3*
Culverts	CD 1 or CD 2 in CC 2*	CD 3 or CD 3 in CC 3**
Ecoducts	CD 1 + CC 1	-
Siding tracks area		CC1
Turnout area	-	CD 3 + CC 1

*- exact solution shall be developed depending on bridge length and exact location.

**- if duct could not be installed in at least 0,8m depth.

10.4.3. Conceptual solution examples

The example cableway solutions shall be applied for all railway sections as described below. In exceptional cases such as presence of other infrastructure or obstacles limiting implementation, conceptual solution deviations shall be coordinated with RB Rail AS. Any design even in the complex track layouts (e.g.

Infrastructure or Rolling stock maintenance facilities, Intermodal terminal, etc..) shall respect all principles spread in the Design Guidelines and cableways shall reach beginning of any turnout.

10.4.3.1. Open line location

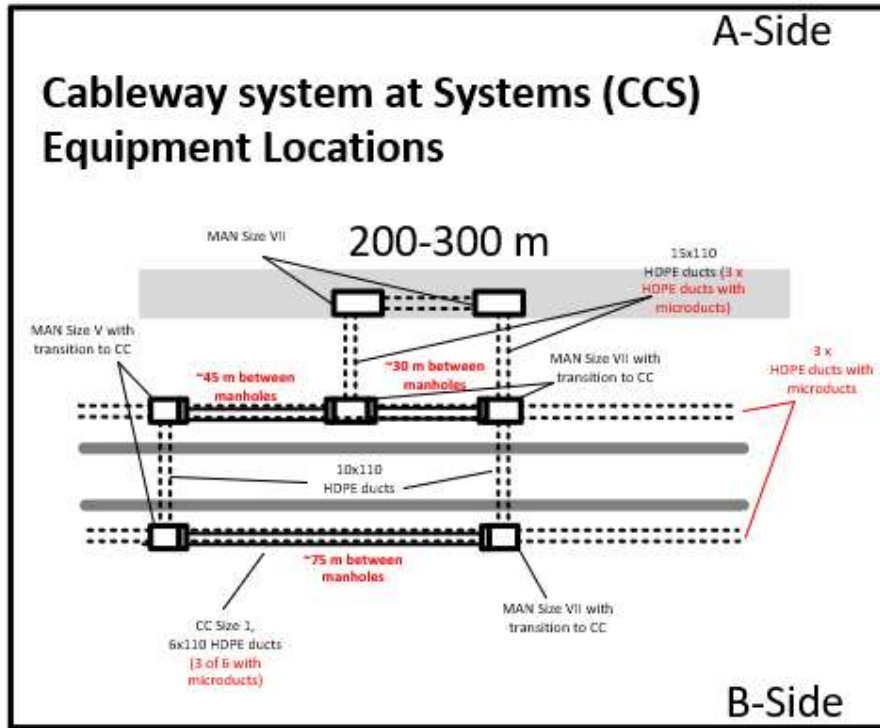

2. CABLEWAYS AT CCS SYSTEM EQUIPMENT LOCATIONS

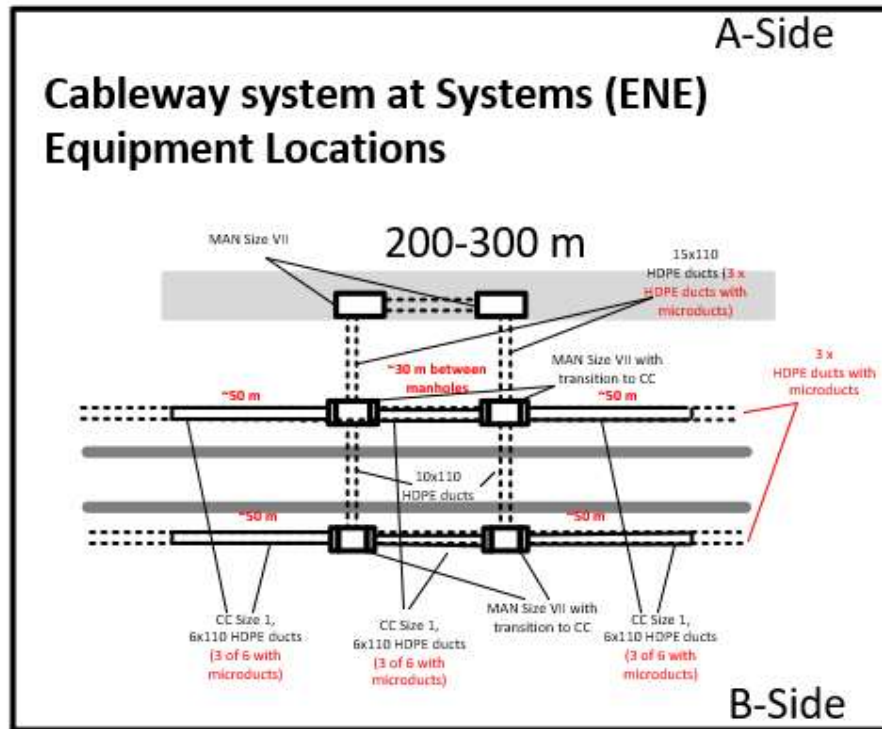

3.

CABLEWAYS AT ENE SYSTEM EQUIPMENT LOCATIONS

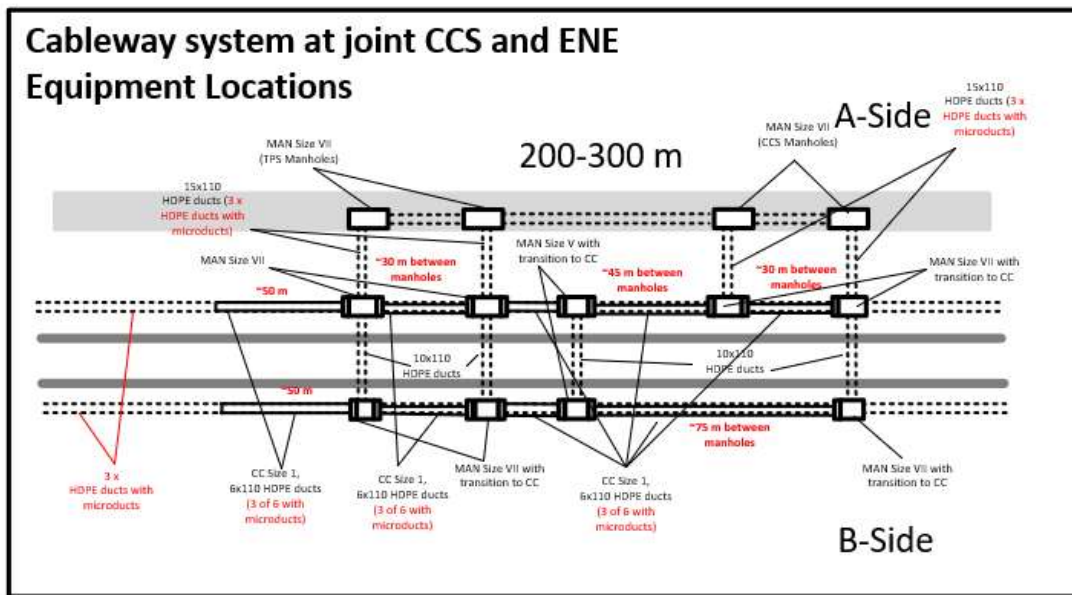

4. CABLEWAYS AT JOINT CCS AND ENE SYSTEMS EQUIPMENT LOCATIONS

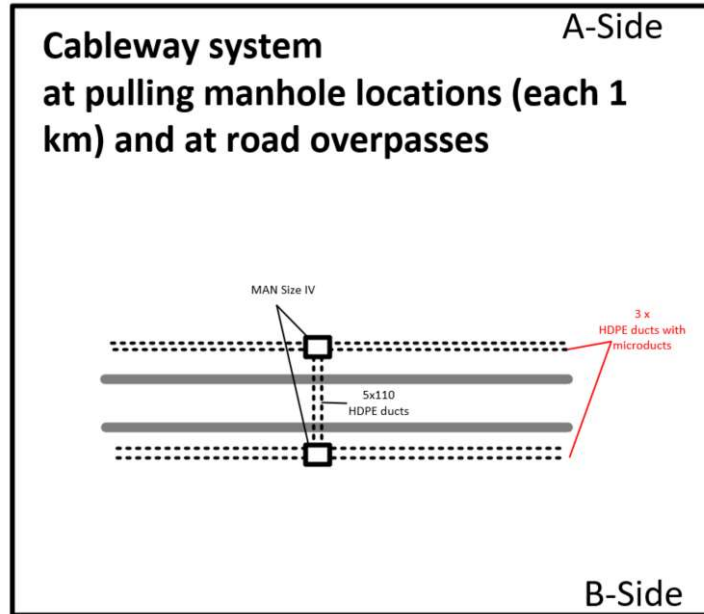

5. CABLEWAYS AT PULLING MANHOLES AND ROAD OVERPASSES

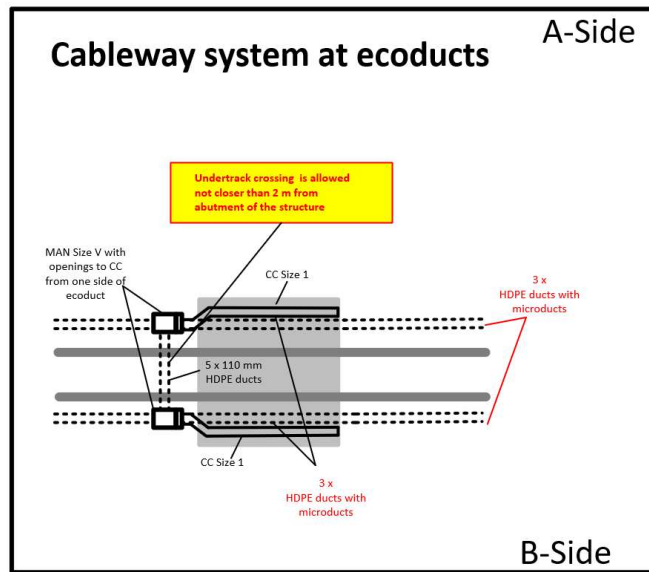

6. CABLEWAYS AT ECODUCTS

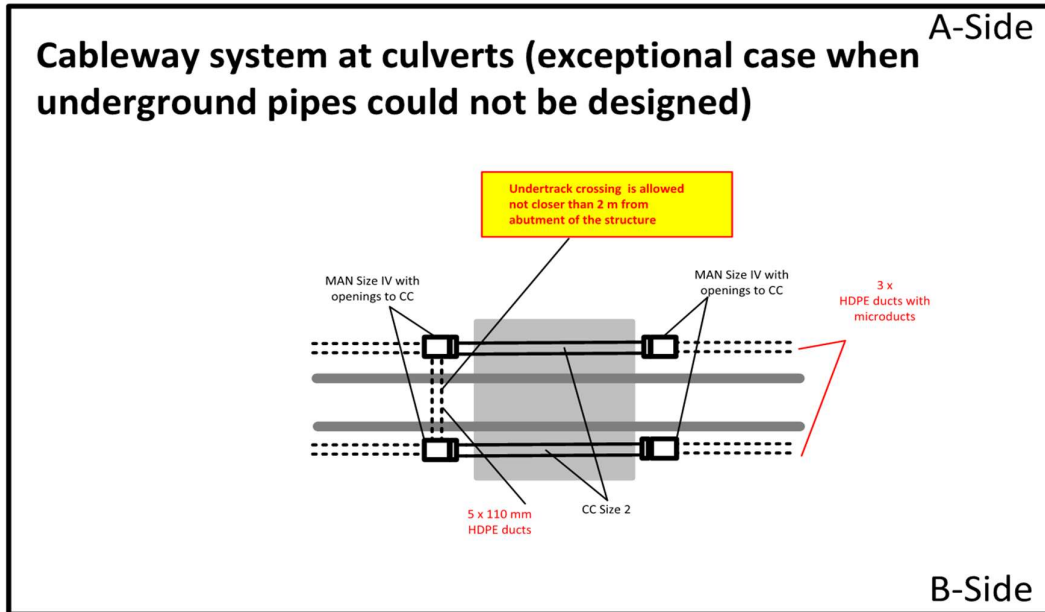

7. CABLEWAYS AT CULVERTS

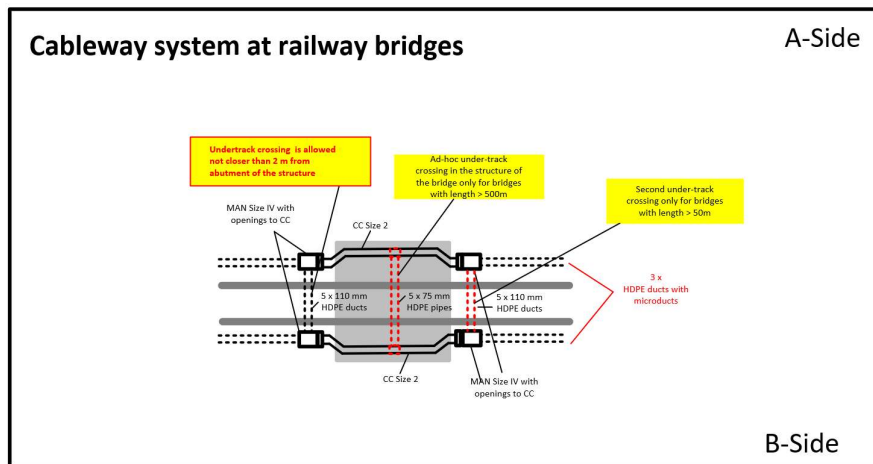

8. CABLEWAYS AT RAILWAY BRIDGES

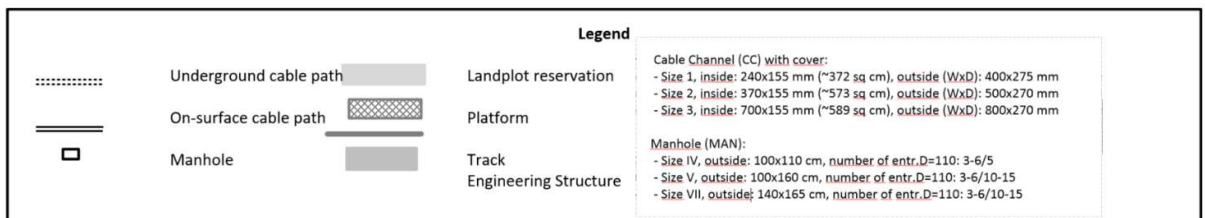

9. LEGEND

10.4.3.2. Station area location

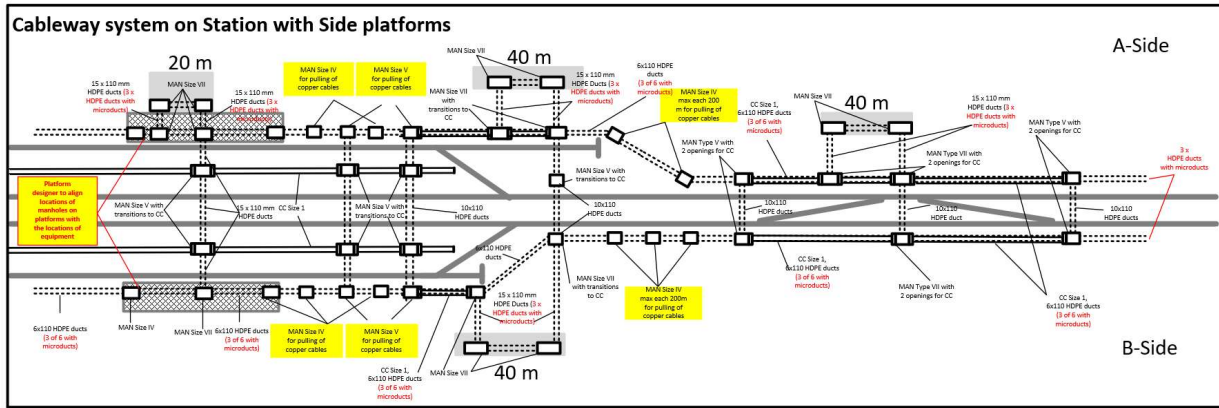

10. CABLEWAYS ON STATION WITH SIDE PLATFORMS

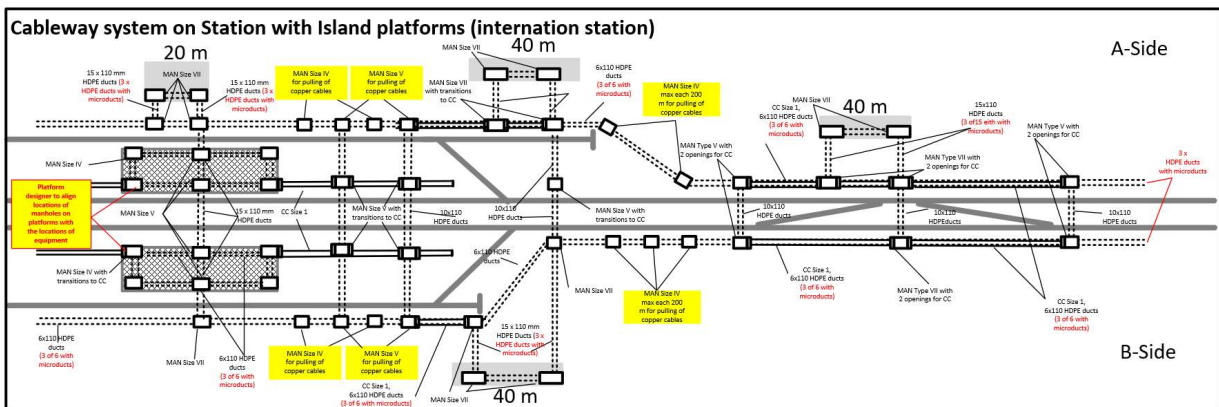

11. CABLEWAYS ON STATION WITH ISLAND PLATFORMS

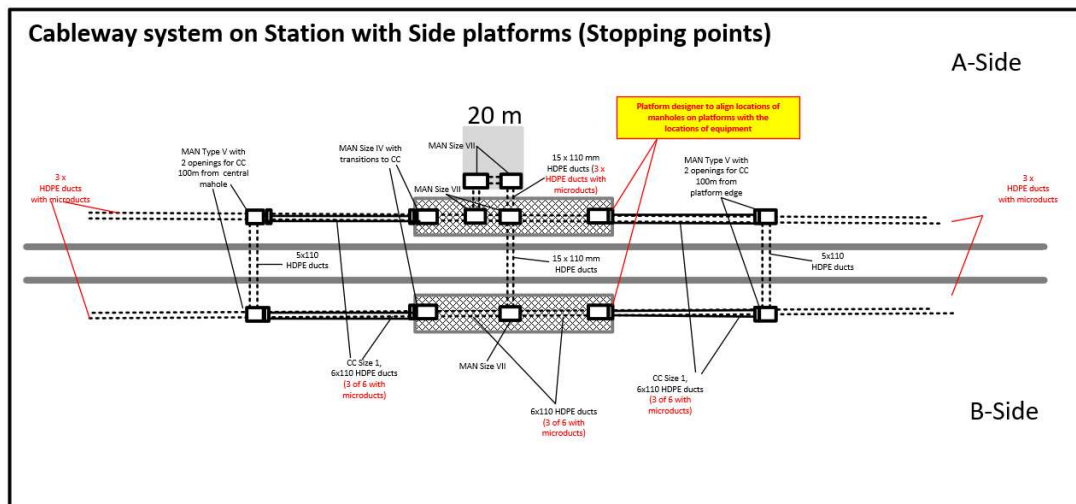

12. CABLEWAYS ON STOPPING POINTS

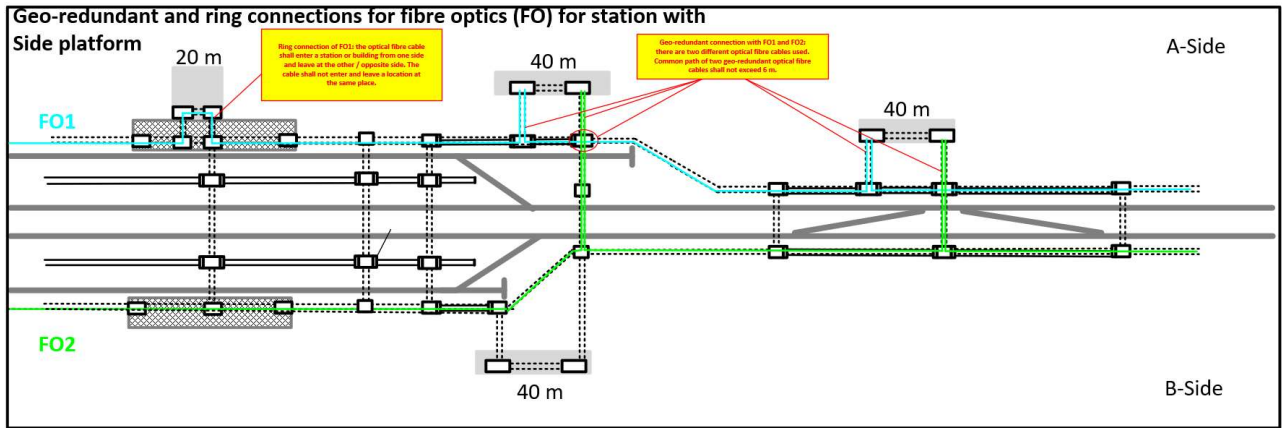

13. GEO-REDUNDANT AND RING CONNECTIONS OF OPTICAL FIBRE CABLE

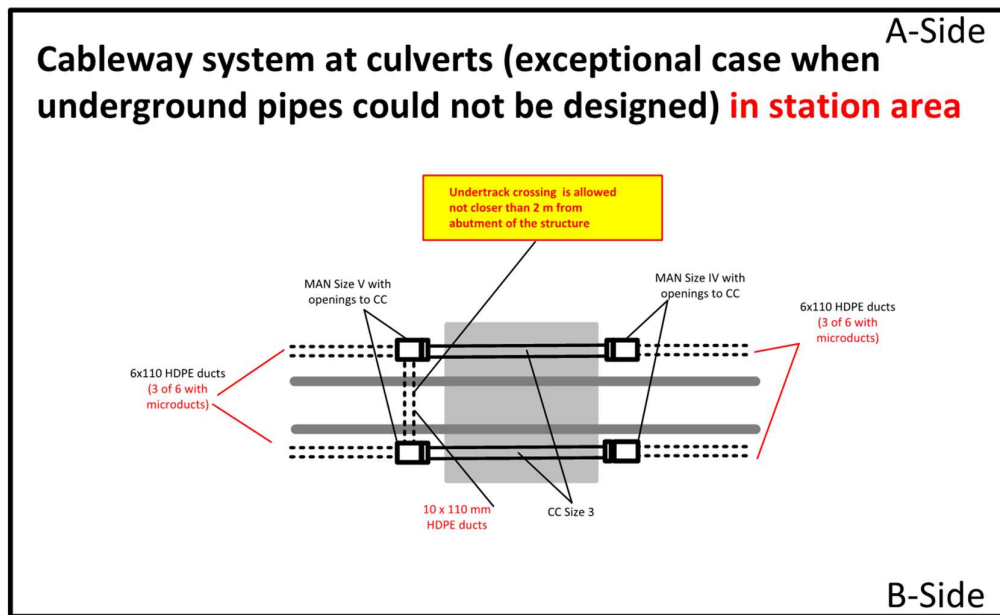

14. CABLEWAYS AT CULVERTS IN STATION AREA

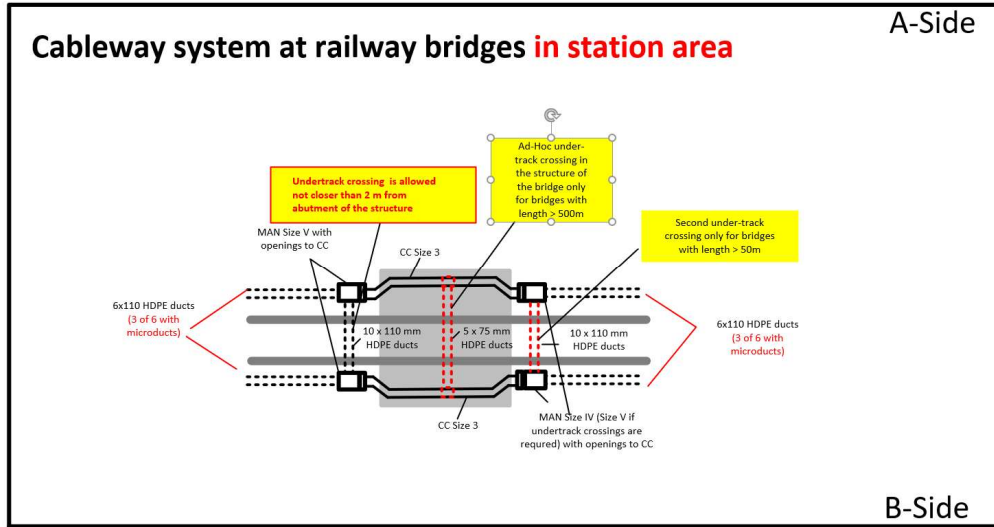

15. CABLEWAYS AT RAILWAY BRIDGES IN STATION AREA

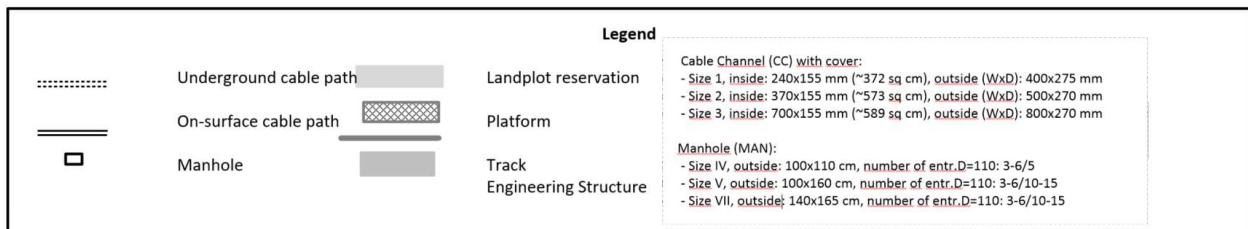

16. LEGEND

11. Design life

The design shall comply with following design life:

- Infrastructure
 - o Earthwork, storm drainage, structure: 100 years
 - o Expansion joint, bearings: 50 years
 - o Track, rail, sleepers, ballast, turnouts, switches, fastening systems: 50 years
 - o Components of the grounding, bonding, and lightning protection system embedded within concrete structures: 100 years
- Systems
 - o Mechanical, Electrical, Plumbing, Ventilation and Fire Protection Systems: 50 years
 - o Traction power supply systems and Overhead Catenary Systems: 50 years
 - o Signalling, telecommunications, SCADA: 30 years
 - o Grounding, bonding, and lightning protection system: 50 years
 - o Battery: 20 years
 - o Cable channels and manholes: 50 years

12. Typical cross sections

Main Line Earthworks	
RBDG-DWG-001	Main line embankment - Double track
RBDG-DWG-002	Main line embankment - Double track - High height (> 12m)
RBDG-DWG-003	Main line cut - Double track - Dry cut (without water table)
RBDG-DWG-004	Main line cut - Double track - Wet cut (with water table)
RBDG-DWG-005	Main line cut - Double track - Dry cut with high height (> 12m) without water table
RBDG-DWG-006	Main line cut in rock formation - Double track - Dry cut with high height (> 12m) with pebble trap
RBDG-DWG-007	Main line - Next to actual exploited line
RBDG-DWG-008	Main line embankment - Simple Track
RBDG-DWG-009	Main line embankment - Passing loop at grade
RBDG-DWG-010	International station
RBDG-DWG-011	Depot / multimodal terminal
RBDG-DWG-012	Main line – next to an operational railway line with limited right of way
Specific cross sections	
RBDG-DWG-020	Main line embankment - Acoustic screen on embankment
RBDG-DWG-021	Main line embankment - Acoustic screen on natural ground
RBDG-DWG-022	Main line embankment - Embankment in flood plain
RBDG-DWG-023	Detail - Draining layer
RBDG-DWG-024	Detail - Protective layer
RBDG-DWG-025	Detail - Draining spur
RBDG-DWG-026	Main line embankment - Acoustic protection by merlon
Technical block	
RBDG-DWG-030	Technical block - Bridge with span
RBDG-DWG-031	Technical block - Culvert with large thickness of cover materials
RBDG-DWG-032	Technical block - Culvert with low thickness of cover materials
Drainage	
RBDG-DWG-033	Drainage - Pipe elevation and plan view
RBDG-DWG-034	Drainage - Pipe under ground level
RBDG-DWG-035	Drainage - Pipe at grade
RBDG-DWG-036	Drainage - Headwall
RBDG-DWG-037	Drainage - Pipe under ground level with lower thickness of covert materials
RBDG-DWG-038	Drainage - Pipe at grade with lower thickness of covert materials
Anti-Penetration Protection Device for highway	
RBDG-DWG-050	Railway in cut or embankment (<3m) Distance to road embankment: 2m < L1 < 6m - Twinning area close to 2m
RBDG-DWG-051	Railway in cut or embankment (<3m) Distance to road embankment: 2m < L1 < 6m - Twinning area close to 6m

RBDG-DWG-052	Railway in cut or embankment (<3m) Distance to road embankment: $2m < L1 < 6m$ - Situation between 2 and 6m
RBDG-DWG-053	Railway in cut or embankment (<3m) Distance to road embankment: $6m < L1 < 8m$
RBDG-DWG-054	Railway in cut or embankment (<3m) Distance to road embankment: $8m < L1 < 17m$ - Recommended situation
RBDG-DWG-055	Railway in cut or embankment (<3m) Distance to road embankment: $8m < L1 < 17m$ - Variant solution
RBDG-DWG-056	Railway in cut or embankment (<3m) Distance to road embankment: $17m < L1 < 30m$
RBDG-DWG-057	Railway in cut or embankment (<3m) Distance to road embankment: $30m < L1 < 50m$
RBDG-DWG-058	Roadway at least 3m lower than the railway
Anti-Penetration protection device for secondary road	
RBDG-DWG-059	Altimetric difference < 1m: merlon with height of 1m + ditch or melon with height of 1,5m - RW on embankment
RBDG-DWG-060	Altimetric difference < 1m: merlon with height of 1m + ditch or melon with height of 1,5m - RW on low cut, low embankment
RBDG-DWG-061	Altimetric difference < 1m: merlon with height of 1m + ditch or melon with height of 1,5m - RW in cut > 0,5m
RBDG-DWG-062	Insufficient space available: Metal or concrete safety device with N2 level - RW on embankment
RBDG-DWG-063	Insufficient space available: Metal or concrete safety device with N2 level - RW on low cut, low embankment
RBDG-DWG-064	Insufficient space available: Metal or concrete safety device with N2 level - RW in cut > 0,5m
High speed line Railway with maintenance road	
RBDG-DWG-065	High speed line Railway with maintenance road
Structures	
RBDG-DWG-070	Viaduct – cross section
RBDG-DWG-071	Overpass – cross section
RBDG-DWG-072	Overpass - elevation
RBDG-DWG-073	Tunnel or cut and cover – cross section

13. Tolerances for the construction

The tolerances for the railway systems and subsystems construction will be defined in a separate document(s).

14. Systems Equipment Locations

This chapter defines requirements on System Equipment Locations which shall be respected by Civil Works Designers as initial land plot reservations. This initial design will be the subject of review and update by Railway Systems Designers responsible for Energy (ENE) and Control, command and signalling (CCS), including non-traction power supply and telecommunications.

14.1. System Equipment Location outside of station and stopping point areas

For the System Equipment Location outside of stations and stopping point areas, Designer shall reserve a land plot on one side of the railway line and design a road access. The minimum width of the land plot shall be 15 m at a minimum distance of 8 meters from the axis of the closest track along the entire System Equipment Location area, in exceptional cases (such as urban areas) the area and distance to closest track axis can be reduced. RB Rail AS provides the list of required System Equipment Location chainages to Designer.

The length of the land plot reservations along the railway line shall be as follows:

- 200 m in station approach area: the distance to the closest neighbouring System Equipment Location is not more than 2 km, or
- 300 m in open line area: the distance to the closest neighbouring System Equipment Location is more than 2 km.

The diagram below provides the details on the land plot reservation area:

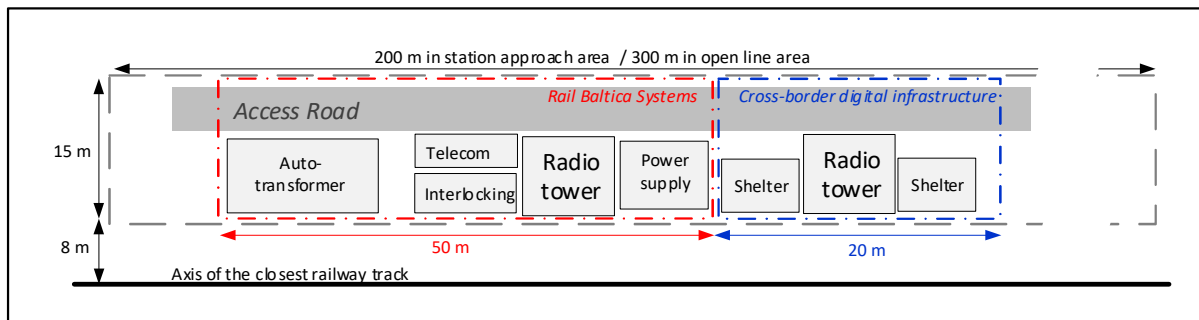

17. LAND PLOT RESERVATION AREA AT SYSTEM EQUIPMENT LOCATIONS

One part of the land plot reservation shall be used for location of following Rail Baltica systems:

- auto-Transformers enclosure with related protection cabinet,
- radio tower and radio-communication equipment,
- telecommunications equipment incl. fiber optic regeneration cabinet,

- interlocking equipment,
- power supply cabinet.

This reservation shall be located inside the railway fenced area (scope of Railway System Designers).

Second part of the land plot reservation shall be used for location of cross-border digital infrastructure systems:

- telecommunications equipment cabinets,
- optional radio tower.

This reservation shall be located inside the railway right-of-way, but outside the railway fenced area.

The design of the fencing system shall be according the following requirements:

- the cross-border digital infrastructure systems shall be implemented in a specific fenced area, separated from railway area;
- The cross-border digital infrastructure systems shall be directly accessible from the access road, in a manner independent from access to railway area;
- The cross-border digital infrastructure systems area shall not constitute an obstacle to the circulation along the railway tracks in the railway area, whether by car if a parallel maintenance road exists, or by foot in other case.

The Designer shall design no land plot reservations but only a road access for balise locations on track sections with the distance between two neighbouring System Equipment Locations more than 2 km. List of balise location chainages is provided by RB Rail AS.

14.2. System Equipment Locations in platform area

For the System Equipment Locations in platform area, Designer shall reserve a land plot of min. 130 square metres with preferred dimensions of 20 x 6,5 meters (in exceptional cases the dimensions can be adjusted to local conditions) on one side of the railway line which has a road access. Land plot reservation shall be used for location of following Rail Baltica systems:

- security system,
- Passengers Information System (PIS),
- power utilities,
- station management utilities.

The diagram below provides the details on the land plot reservation area:

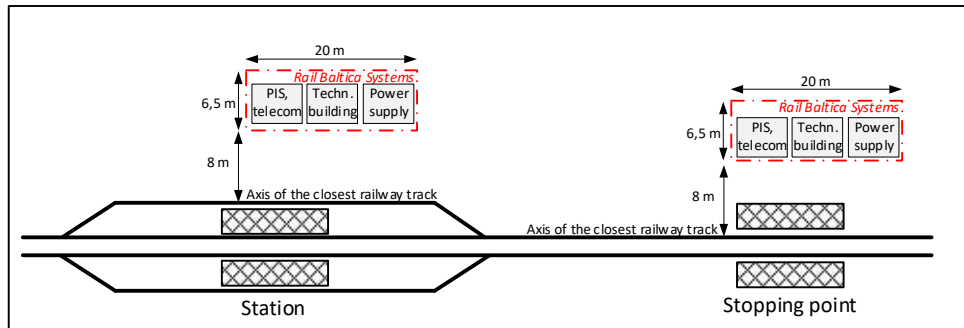

18. LAND PLOT RESERVATION AREA IN STATIONS AND STOPPING POINTS

Due to the fact that railway systems may be in future implemented inside the station building, the land plot reservation shall be made next to the planned location of the building.

14.3. System Equipment Locations in crossover and station turnout areas

For the System Equipment Locations in crossover and station turnout areas, Designer shall reserve a land plot of min. 260 square metres and the min. width of 6,5 m on any side of the railway line which has a road access. The distance to the axis of the closest track shall be not less than 8 meters, as depicted in the diagram below. The preferable location of the land plot shall be close to the turnouts marked with the sign "T". It shall be located outside of the danger area behind the dead-end protection track.

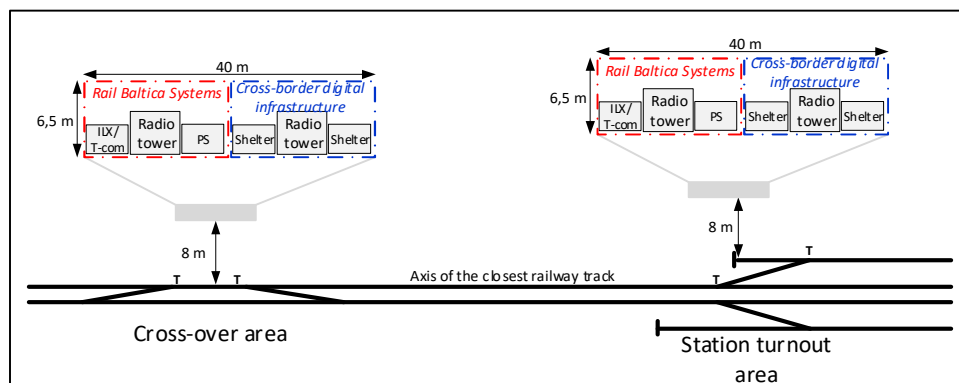

19. LAND PLOT RESERVATION IN CROSSOVER AND STATION TURNOUT AREAS

Half of the land plot reservation shall be used for location of Rail Baltica systems:

- radio tower and radio-communication equipment,
- telecommunications equipment incl. fiber optic regeneration cabinet,
- interlocking equipment,
- power supply cabinet.

This reservation shall be located inside the railway fenced area.

Another half of the land plot reservation shall be used for location of cross-border digital infrastructure systems:

- telecommunications equipment cabinets,
- optional radio tower.

This reservation shall be located inside the railway right-of-way, but outside the railway fenced area.

The design of the fencing system shall be according the following requirements:

- the cross-border digital infrastructure systems shall be implemented in a specific fenced area, separated from railway area;
- the cross-border digital infrastructure systems shall be directly accessible from the access road, in a manner independent from access to railway area;
- the cross-border digital infrastructure systems area shall not constitute an obstacle to the circulation along the railway tracks in the railway area, whether by car if a parallel maintenance road exists, or by foot in other case.

In cases when land plots reservations required above could be designed only at the distance of more than 15 m from the axis of the closest track, Designer shall make provision for an additional area with the size of 0.4x0.6x1m at the distance of 3,8 m from the axis of the closest track for location of the one point heating cabinet for each group of 5 switches. Several areas could be located as close to each other as possible. The distance between the area and the most remote switch blades shall not exceed 300 m.

APPENDIX 1: Technical specifications for the supply of multi-ducts, cable ducts, manholes and cable channels for construction of Rail Baltica railway line

1. Introduction

These Technical Specifications define requirements on the manufacture and supply of cable guiding and supporting elements intended for cable installation including different cable system elements (hereinafter called Cable system elements) for use in the design and construction of Rail Baltica line: Multiducts, Ducts, Manholes and Cable channels.

This specification covers only Cable system elements for outdoor cable installation.

This specification does not cover cable system elements for indoor installation.

2. Application

The objective of this section is to give an overview of required Cable system elements for installation of railway signalling, communications and power supply cables.

The specific types of Cable system elements are used depending on the required Cable system capacity, as described in the Chapter 10 of Rail Baltica Design Guidelines, General requirements RBDG-MAN-012-0108.

Multiduct and Duct

- 2.1.1 Multiducts and Ducts will be installed parallel to the tracks and are designed in three configurations depending on the number of cables to be installed, see Figure 1:

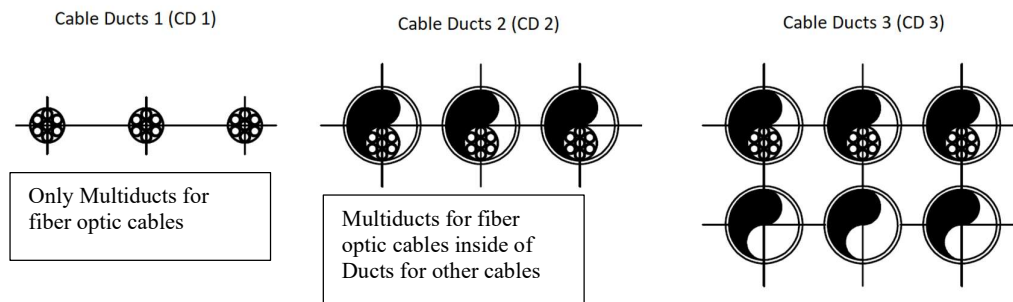

Multiduct and cable Ducts configurations.

- 2.1.2 Configuration CD 1 consists of 3 HDPE Multiducts. Configuration CD 2 consists of 3 HDPE Multiducts each installed in HDPE duct of a superior diameter. Configuration CD 3 consists of Configuration CD 2 and in addition 3 empty HDPE ducts.
- 2.1.3 At certain manholes, under-track crossings as deviations from the main cable route parallel to the tracks are designed. Three different configurations are used, see Figure 2:

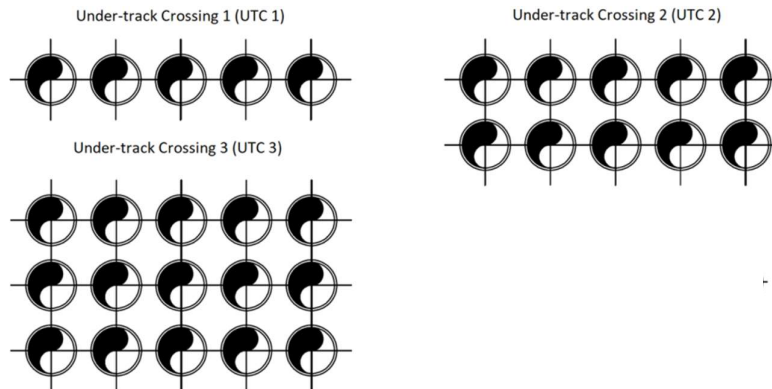

- 2.1.4 Configuration UTC 1 consists of 5 HDPE ducts. Configuration UTC 2 consists of 10 HDPE ducts. Configuration UTC 3 consists of 15 HDPE ducts.
- 2.1.5 Detailed requirements on dimensions of Multiduct and Duct are described below in chapter 5.

Manhole incl. transition elements to Cable channel

- 2.2.1 Three types of Manholes (Manhole types IV, V and VII) are used along the tracks to access the cables and to allow the cable transition between different Multiducts, Ducts and the precast Cable channels. The dimensions of each type of Manhole are described below in chapter 5.
- 2.2.2 Manholes shall be produced in different configurations to adapt the depth of the Manhole and allow connection of the on-surface concrete Cable channels, if required in design.
- 2.2.3 Manhole lids shall be designed and produced in a way that they cannot fall into the Manhole and harm personnel, cables or equipment.
- 2.2.4 Manhole shall allow of installation of cable shelves inside it.
- 2.2.5 Manhole structure shall ensure enough space for ladders application for personnel access inside the Manhole.
- 2.2.6 Different Elements for the transition from Manhole to Cable channel shall be produced.

Cable channel incl. straight, turned and elevated elements

- 2.3.1 Cable channel consists of U-shaped Precast concrete elements with lid which is installed on the surface level.
- 2.3.2 Cable channel is installed on railway bridges and culverts, in sections under ecoducts and road overpasses, in stations, crossovers and railway system equipment locations.
- 2.3.3 Three different sizes of Cable channel elements shall be delivered:
- 2.3.3.1 Straight cable channel element of cable channels type CC1, CC2, CC3;
 - 2.3.3.2 15- and 30-degree cable channel turned element for types CC1, CC2, CC3;
 - 2.3.3.3 15- and 30-degree cable channel elevation element for types CC1, CC2, CC3.

2.3.4 Detailed requirements on dimensions of Cable channel are described below in chapter 5.

3. Requirements

Multiduct

- 3.1.1 Multiduct shall have following dimensions and characteristics:
 - 3.1.1.1 Multiduct shall be from High Density Polyethylene (HDPE);
 - 3.1.1.2 Multiduct shall comply with IEC 60794-1-22; EN 50411-6-1:2011; IEC 60794-1-21 or other industry applicable standards;
 - 3.1.1.3 Outer diameter of 49.5mm, +10%/-10%;
 - 3.1.1.4 Sheath thickness: not less than 0.9 mm;
 - 3.1.1.5 Number of Microducts of inferior diameter: 7 pcs;
 - 3.1.1.6 Outside/Inside diameter of Microducts: 16/12 mm;
 - 3.1.1.7 Microducts shall be suitable for installation of fibre optic cable with diameter of 6-9 mm using blowing method for a distance not less than 2100m with 1,2 MPa (12 bar) air pressure;
 - 3.1.1.8 Multiduct length on single drum at least 1200m;
 - 3.1.1.9 An indicative Multiduct order length on a single drum: from 650m till 1200m. Final Multiduct length on each drum shall be defined by Client prior to ordering. The following approach will be used for ordering multiducts:
 - a) 95 % of total amount of multiduct length will be planned to order with 1 200 m length on drum;
 - b) 5 % of multiduct length will be planned to order in range between 650 m till 1 200 m length on drum.
 - 3.1.1.10 Each Multiduct drum shall be delivered with Microduct end caps (seals);
 - 3.1.1.11 Supplier shall provide additional sets of airtight Microduct joint connectors, airtight Microduct end caps (seals) and required connection tools when requested by the Client;
 - 3.1.1.12 Microduct joint connectors for 16mm Microducts shall fit for proposed Microducts of Multiducts and provide air pressure resistance class not less than 12 bar.
 - 3.1.1.13 Multiduct bending radius shall be not less than 900mm, Multiduct should still be possible to bend much more than that during installation to get it installed to manholes.
- 3.1.2 Indicative overview of an Multiduct is provided on the figure 3 below:

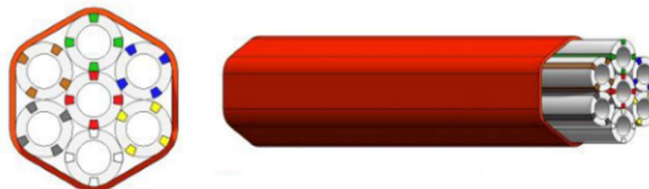

Multiduct overview.

- 3.1.3 Required load classes for Multiduct shall be as follows:
 - 3.1.3.1 750 N of compression strength for installation along railway;

- 3.1.3.2 Tensile load 7000N;
- 3.1.3.3 Suitable for internal pressure 2,0 MPa (20 bar) without becoming deformed;
- 3.1.3.4 Impact strength 5J;
- 3.1.4 Aimed for installation underground and in cable canalization;
- 3.1.5 Installation temperature range from -10 till +50 degree of Celsius;
- 3.1.6 Storage and operation temperature range from -30 till +60 degree of Celsius.
- 3.1.7 Multiduct surface shall be as follows:
 - 3.1.7.1 Multiduct outer sheath must be in orange colour;
 - 3.1.7.2 Multiduct inner microducts must be in following 7 colours: red, green, blue, yellow, white, grey, brown;
 - 3.1.7.3 Outer sheath shall be smooth for convenient Multiduct installation inside Ducts;
 - 3.1.7.4 Inner surface of inner Microduct shall be smooth for convenient optical fibre cable installation using blowing method.
- 3.1.8 The design working life for Multiduct shall be not less than 50 years.
- 3.1.9 For connection of a Multiduct with the outer diameter 49.5mm +10/- 10%, the Multiduct Supplier shall provide Multiduct connectors to 110 mm openings for Multiduct entering into Manholes. Connectors shall provide not less than 0,5 bar water resistance.
- 3.1.10 Multiducts shall provide anti rodent protection for installed cables. Metal protection element application in Multiduct is not allowed.

Duct

- 3.2.1 Duct shall have following dimensions and characteristics:
 - 3.2.1.1 Duct shall be from High Density Polyethylene (HDPE) or polypropylene (PP);
 - 3.2.1.2 HDPE Duct shall comply with EN 61386-1 and EN 61386-24 regulations;
 - 3.2.1.3 Duct shall have an outer diameter of 110 mm (tolerance +2,0/0 mm);
 - 3.2.1.4 Duct wall thickness must be at least 3 mm;
 - 3.2.1.5 Length of a single Duct piece shall be 6 m;
 - 3.2.1.6 Duct for installation along the tracks (Duct 750N) shall have inner diameter not less than 91.0 mm;
 - 3.2.1.7 Duct for under-track installation (Duct 1250N) shall have inner diameter not less than 88.0 mm;
 - 3.2.1.8 Each Duct shall be delivered with watertight connection joint and special connection materials and tools if required;
 - 3.2.1.9 Each Duct connection joint shall provide water resistance of not less than 0,5 bar;
 - 3.2.1.10 Watertight end caps for Ducts shall be available from Supplier.
- 3.2.2 Defined load classes for Ducts according to EN 61386-24 shall be as follows:
 - 3.2.2.1 750 N of compression strength for installation along railway;
 - 3.2.2.2 1250 N of compression strength for installation in under track crossings;
 - 3.2.2.3 Impact strength class Normal
 - 3.2.2.4 Aimed for installation underground and in concrete;
- 3.2.3 Installation temperature range from -10 till +50 degree Celsius;

- 3.2.4 Storage and in service operation temperature range from -30 till +60 degree Celsius;
- 3.2.5 Duct surface shall be as follows:
 - 3.2.5.1 Cable Duct outer sheath colours:
 - a) Orange colour for cable ducts with 750 N compression strength;
 - b) Yellow colour for cable ducts with 1250 N compression strength;
 - 3.2.5.2 Outer sheath shall be smooth or ribbed for convenient installation underground and in Cable channels;
 - 3.2.5.3 Inner surface of Ducts shall be smooth for convenient cable installation.
- 3.2.6 The design working life for Duct is minimum 50 years
- 3.2.7 Indicative overview of a Duct is provided on the figure below:



Duct overview.

Manhole

- 3.3.1 Manhole shall consist of modular elements, which shall be connected to each other watertight on the site. This shall allow configuring the Manhole's depth and layout of connection elements (inlets).
- 3.3.2 The schematic overview of the Manhole structure is provided in the Figure 5 below:

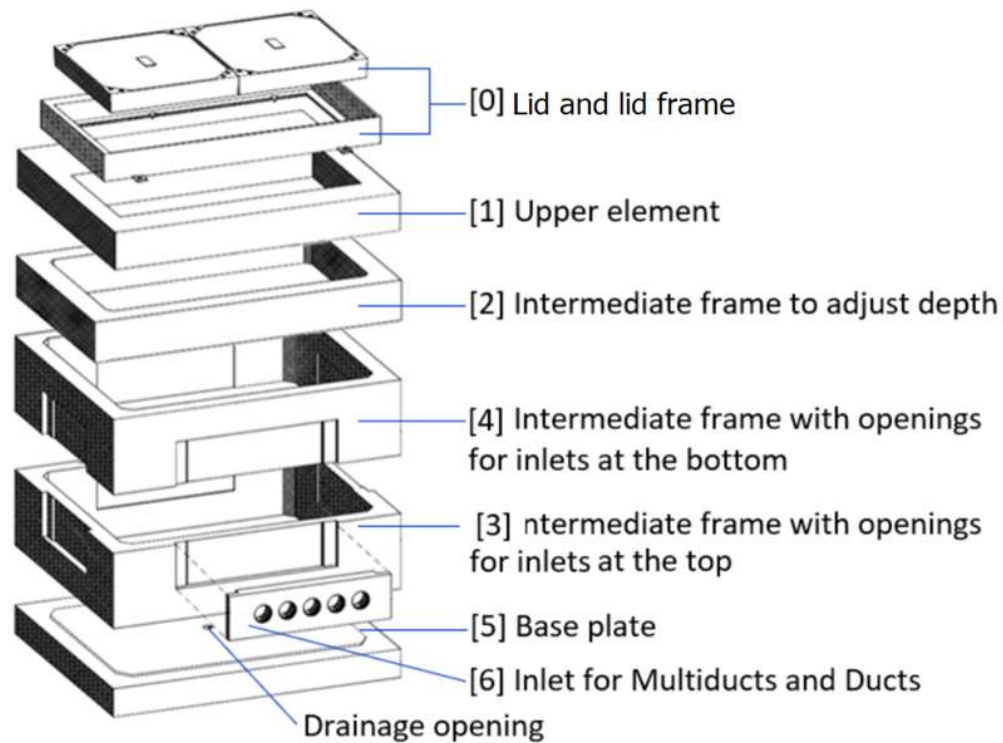

Manhole elements.

- 3.3.3 The modular Manhole shall include the following elements:
- 3.3.3.1 [0] Manhole lid (non-ventilated), and lid frame which is connected to the upper element. The lid shall be single or double depending on the type of the Manhole, as described further in chapter 2;
 - 3.3.3.2 [1] Upper plate element with a height of 200 mm (for Manhole IV 3 – only 80 mm) with opening for installation of the lid frame. The opening shall have dimensions of 700 x 700 mm for Manhole IV and 700 x 1400 mm for Manhole V and VII;
 - 3.3.3.3 [2] Intermediate frame with a height of 200 mm for adjustment of the depth of the Manhole (multiple elements could be applied, as depicted in Figure 6);
 - 3.3.3.4 [3] Intermediate frame with a height of 400 mm with predetermined 4 breaking points (at the bottom of each side of the frame) for placing inlets;
 - 3.3.3.5 [4] Intermediate frame with a height of 400 mm with predetermined 4 breaking points (at the top of each side of the frame) for placing inlets;
 - 3.3.3.6 [5] Base plate with a height of 100 mm and an opening in the middle for connection of a drainage pipe.
 - 3.3.3.7 [6] Inlets with various size and number of openings for installation at breaking point locations.
- 3.3.4 All Manhole element joint connections of assembled Manhole shall be watertight, with resistance not less than 0,5 bar according to EN1917. Manhole Supplier shall include

manuals for mounting of the Manhole elements in technical documentation of all types of the manholes.

3.3.5 There shall be supplied 3 types of Manholes (type IV, V and VII). Each type has different horizontal dimensions (length and width). The depth of the Manholes varies for type IV and V which is indicated with Arabic digits 1, 2 or 3:

- 3.3.5.1 Manhole IV with external dimensions 1,1 x 1 x 1,3 m (L x W x D);
- 3.3.5.2 Manhole IV.2 with external dimensions 1,1 x 1 x 1,5 m (L x W x D);
- 3.3.5.3 Manhole IV.3 with external dimensions 1,1 x 1 x 0,48 m (L x W x D);
- 3.3.5.4 Manhole V with external dimensions 1,60 x 1 x 1,5 m (L x W x D);
- 3.3.5.5 Manhole V.2 with external dimensions 1,60 x 1 x 1,9 m (L x W x D);
- 3.3.5.6 Manhole VII with external dimensions 1,65 x 1,4 x 1,5 m (L x W x D).

3.3.6 Described above six (6) Manhole variations are depicted below in Figure 6 and Figure 7:

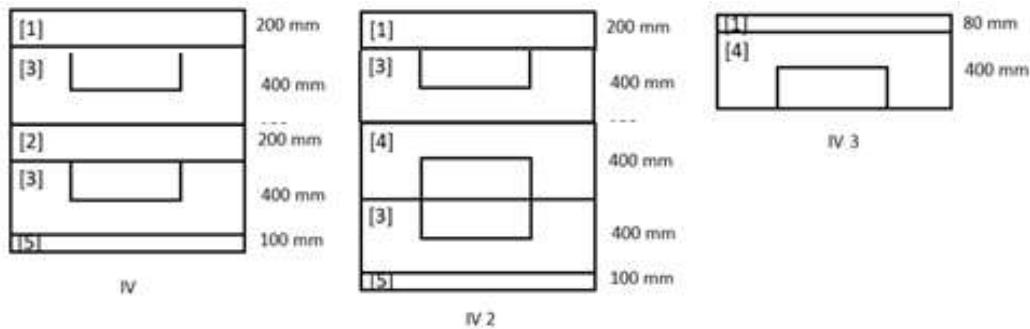

Manholes IV.1, IV.2 and IV.3

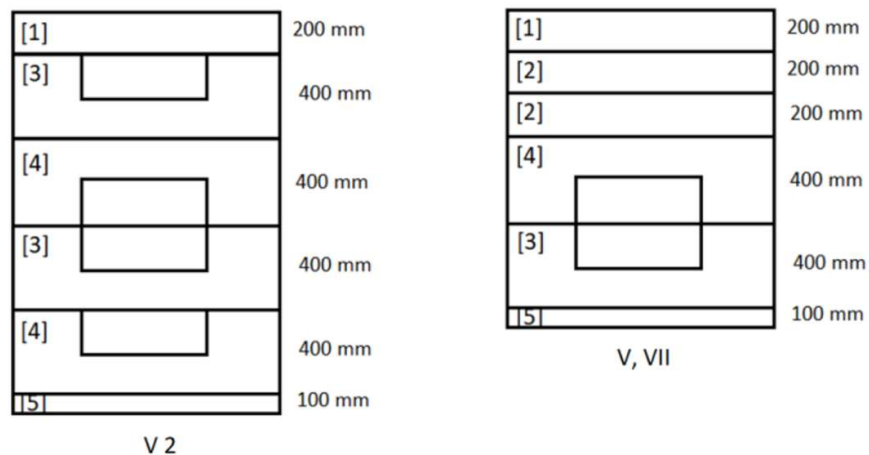

Manholes V.2, V.1 and VII.1.

3.3.7 Different sequence of the elements or more elements in the described above six (6) Manhole variations shall be as well provided, if it is requested by the Client.

3.3.8 Drainage opening in the middle of the Base plate shall ensure watertight connection of the drainage duct with resistance not less than (0,5 bar), preventing the accumulation of water inside the Manhole.

- 3.3.9 Grounding wire entry opening with diameter of 30mm in the Upper plate element shall ensure watertight connection with water pressure resistance not less than (0,5 bar), preventing the accumulation of water inside the Manhole.
- 3.3.10
- 3.3.11 Thickness of reinforced walls of each Manhole element shall be not more than 100 mm, and not more than 50 mm (without reinforcement) in places for installation of connection elements (inlets) and drainage duct installation.

Material

- 3.3.12 Manholes shall be produced in accordance with EN 1917;
- 3.3.13 All elements of Manhole and transition elements shall be made of reinforced precast concrete complying with provisions of EN 206-1 + Corresponding National Annexes.;
- 3.3.14 Both the Transition to Cable channels and their lids shall be made of reinforced precast concrete complying with provisions of EN 206-1 + Corresponding National Annexes; All elements of Manhole and transition elements shall be made of reinforced precast concrete complying with provisions of EN 206-1 + Corresponding National Annexes.
- 3.3.15 All Manhole elements shall be provided with reinforcement, in order to support the bending and ground pressure force and impact efforts in their placement and handling. Manhole upper plate and lids shall allow for the transit of people during its useful life without causing it to break.
- 3.3.16 Both the lid and the Manhole elements shall be produced in such a way to avoid water ingress to the Manhole.
- 3.3.17 Concrete for all Manhole types shall comply with standard EN 206.
- 3.3.18 Manholes elements for installation on passenger platforms shall be designed for operation with de-icing salts application during wintertime.

Lid and Lid frame [1]

- 3.3.19 Manhole lid shall allow easy opening with the appropriate tools for maintenance purposes.
- 3.3.20 Manhole lid and lid frame shall be delivered in following solutions:
 - 3.3.20.1 Single lid for Manhole type IV, as depicted on the Figure 8 left and Double lid for Manhole types V and VII, as depicted on the Figure 8 right with the lid frame height 75 mm.

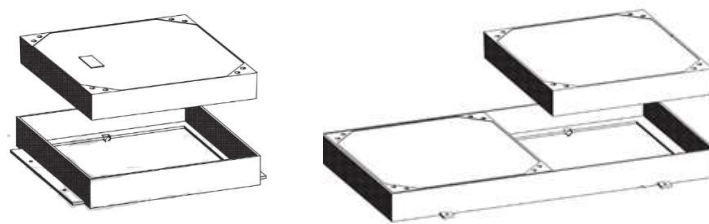

Left: single lid for Manhole IV, right: double lid for Manholes V and VII.

- 3.3.20.2 Single lid for Manhole type IV and double lid for Manhole type V and VII with lid frame integrated in the Manhole upper element [1], as depicted on the Figure 9 in order to implement a top of the Manhole at the same level as the top of the transition element to the cable channel.

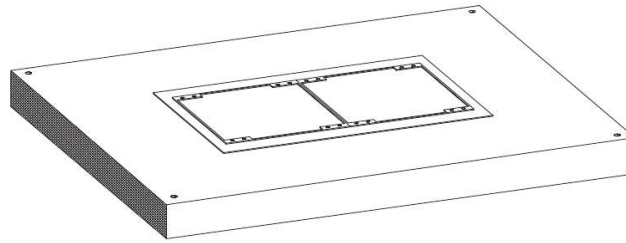

Double lid integrated in the Manhole upper element [1]

3.3.20.3 Single lid for Manhole type IV, as depicted on the Figure 10 above left and Double lid for Manhole types V and VII, as depicted on the Figure 10 above right for installation of the 10 cm high paving surface on Manhole lid and upper element.

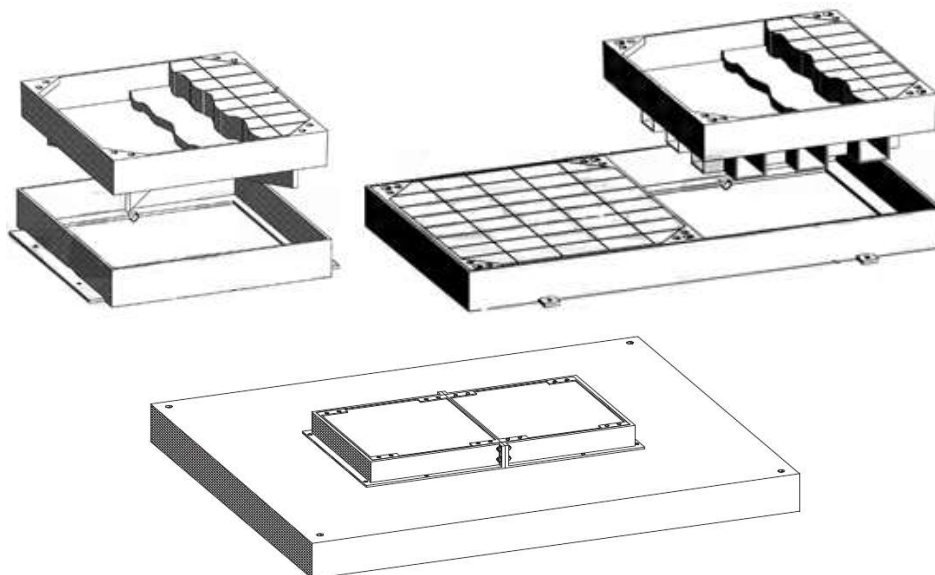

*Above: Single and double Manhole lids with pavement, below:
Manhole upper element for installation of pavement*

- 3.3.21 Manhole lid lifting tool allowing one person open the lid shall be provided.
- 3.3.22 Manhole lock shall be delivered for all Manhole lids, and the contractor must provide a selfdeclaration that the manhole covers withstand long-term (at least 5 minutes) continuous burglary tests with medium-strength tools (e.g. crowbars, larger screwdrivers).
- 3.3.23 Load classes for Manhole lids shall be as follows:
 - 3.3.23.1 Manhole lids shall provide with load class of B125, EN 124:2015;
 - 3.3.23.2 Transition to Cable channel lids shall provide load strength of 10 kN / m² without the possibility of traffic;
 - 3.3.23.3 Manholes shall be designed with minimal crushing load 300 kN.

Inlet for connection of Multiducts and Ducts [6]

3.3.24 Inlets for ducts shall allow connection of Multiducts and Ducts to the Manhole when installed in the predefined breaking points.

3.3.24.1 Connection elements for installation on the short side of the Manhole, as depicted on the Figure 12, shall meet following requirements:

- 3.3.24.1.1 Element with 3 openings to accommodate 3 Ducts of 110 mm outer diameter for installation in the single predetermined breaking point of the element [3] or [4] (see figure 5);
- 3.3.24.1.2 Element with 2 openings to accommodate 2 Ducts of 160 mm outer diameter for installation in the single predetermined breaking point of the element [3] or [4] (see figure 5);
- 3.3.24.1.3 Element with 9 openings to accommodate 9 Ducts of 110 mm outer diameter for installation in the two adjacent predetermined breaking points of the elements [3] and [4] (see figure 5);
- 3.3.24.1.4 Element with 9 openings to accommodate 6 Ducts of 110 mm outer diameter and 2 Ducts of 160 mm outer diameter for installation in the two adjacent predetermined breaking points of the elements [3] and [4] (see figure 5);
- 3.3.24.1.5 Horizontal distance between Ducts centres shall be not less than 140 mm for 110mm duct openings
- 3.3.24.1.6 Horizontal distance between Ducts centres shall be not less than 200 mm for 160mm duct openings;
- 3.3.24.1.7 Openings shall be equipped with the duct coupling element which shall provide not less than 0,5 bar water resistance;
- 3.3.24.1.8 Supply of the element with 9 openings shall include 3 sealing breakers with outer diameter of 110 mm for closing of the not used openings installed on top of opening row. Sealing breakers shall provide not less than 0,5 bar water resistance;
- 3.3.24.1.9 Supply of the element with 8 openings shall include 3 sealing breakers with outer diameter of 110 mm and 2 sealing breakers with outer diameter of 160 mm for closing of the not used openings installed on top of opening row. Sealing breakers shall provide not less than 0,5 bar water resistance.
- 3.3.24.1.10 For connection of a Multiduct with the outer diameter 49.5mm +10%/-10%, the Multiduct Supplier shall provide Multiduct connectors to 110 mm openings for Multiduct entering into Manholes. Connectors shall provide not less than 0,5 bar water resistance.

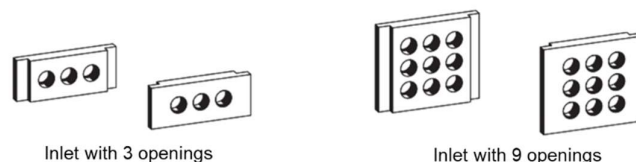

Connection elements with 3 and 9 openings

3.3.24.2 Connection elements for installation on the long side of the Manhole, as depicted on the Figure 13, shall meet following requirements:

- 3.3.24.2.1 Element with 5 openings to accommodate 5 Ducts of 110 mm outer diameter for installation in the single predetermined breaking point of the element [3] or [4] (see figure 5);
- 3.3.24.2.2 Element with 3 openings to accommodate 3 Ducts of 160 mm outer diameter for installation in the single predetermined breaking point of the element [3] or [4] (see figure 5);
- 3.3.24.2.3 Element with 15 openings to accommodate 15 Ducts of 110 mm outer diameter for installation in the two adjacent predetermined breaking points of the elements [3] and [4] (see figure 5);
- 3.3.24.2.4 Element with 13 openings to accommodate 10 Ducts of 110 mm and 3 Ducts of 160 mm outer diameter for installation in the two adjacent predetermined breaking points of the elements [3] and [4] (see figure 5);
- 3.3.24.2.5 Horizontal distance between Ducts centres shall be not less than 14 cm for 110mm duct openings;
- 3.3.24.2.6 Horizontal distance between Ducts centres shall be not less than 200 mm for 160mm duct openings;
- 3.3.24.2.7 Openings shall be equipped with the duct coupling element which shall provide not less than 0,5 bar water resistance.
- 3.3.24.2.8 Supply of the element with 15 openings shall include 5 sealing breakers with outer diameter of 110 mm for closing of the not used openings installed on top of opening row. Sealing breakers shall provide not less than 0,5 bar water resistance.
- 3.3.24.2.9 Supply of the element with 13 openings shall include 5 sealing breakers with outer diameter of 110 mm and 3 sealing breakers with outer diameter of 160 mm for closing of the not used openings installed on top of opening row. Sealing breakers shall provide not less than 0,5 bar water resistance.
- 3.3.24.2.10 For connection of a Multiduct with the outer diameter 49.5mm +10%/-10%, the Multiduct Supplier shall provide Multiduct connectors to 110 mm openings for Multiduct entering into Manholes. Connectors shall provide not less than 0,5 bar water resistance.

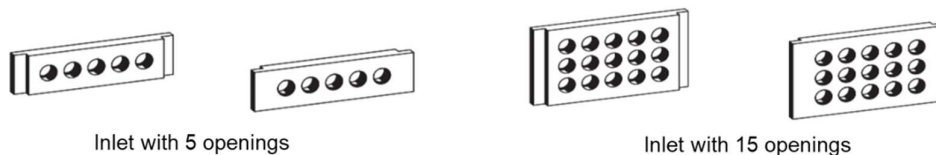

Connection elements with 5 and 15 openings

- 3.3.24.2.11 In addition to the connection elements described in previous chapters, Supplier shall design and manufacture up to 6 (six) different types of connection elements for connection of ducts with larger outer diameter (i.e. 160 mm and 200 mm). The exact layout shall be agreed with Principal after the signature of the Contract.

Transition element for transition from Manhole to a Cable channel

3.3.25 Transition of cables from a Manhole to a Cable channel is implemented by means of a transition element. Two types of Transitions to Cable channel elements (TCC-1 and TCC-2) will be used along the route depending on the type of Cable channel to which they are connected, depicted on the Figure 14.

3.3.25.1 TCC-1 element shall be supplied with external dimensions of 0,48 m (min. 0,40m internal) height, 0,55 m (min. 0,40m internal) length (parallel to the track) and 0,84 m (min. 0,70m internal) width (perpendicular to the track). for cable transition from Manhole to precast Cable channel CC 1.

3.3.25.2 TCC-2 element shall be supplied with external dimensions of 1,28 m (min. 1,20m internal) height, 1,56 m length (min. 1,20m internal) (parallel to the track) and 0,84 m (min. 0,70m internal) width (perpendicular to the track) for cable Ducts and cable transition from Manhole to precast Cable channel CC 2 or CC 3.

3.3.25.3 The lids of TCC-1 and TCC-2 shall be designed as integrated lids with the length of 500 mm in order to ease its handling;

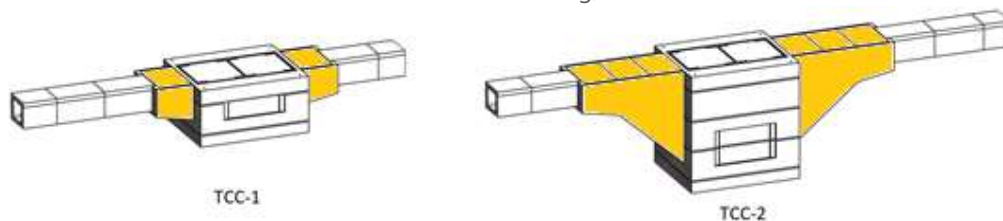

Transition to Cable channel elements. TCC-1 and TCC-2 (in orange)

3.3.26 Manhole surface shall be as follows:

3.3.26.1 All surfaces of concrete elements must have a uniform texture and be free of pits;

3.3.26.2 All elements shall be produced in reverse state to reach better strength for the structure;

3.3.26.3 All surface elements shall be produced without getting loops used for element lifting and transportation;

3.3.26.4 Manhole upper part, Manhole lid and lids of Transition to cable channel elements shall have a non-slippery surface.

3.3.27 Manhole elements shall be not coloured.

3.3.28 The design working life of Manholes, and all Manhole lid metal parts shall be not less than 50 years.

Cable shelves

3.3.29 All Manholes after installation will be equipped with cable shelves for Multiduct and cable organization (please refer to Figure 15) which shall be fixed on the walls of the Manhole. Exact location of cable shelves fixings, its height and number of hooks for each type of the Manhole will be coordinated by the Principal.

3.3.30 Cable shelf will be procured and delivered through a separate procurement.

- 3.3.31 Manhole Supplier shall design manhole. The manhole Supplier shall interface with the Principal and design the manhole elements in a way that these allow later mounting of cable shelves according to requirements below:
- 3.3.31.1 At least 4 shelves shall be located on the longest side of the Manhole;
 - 3.3.31.2 Consistent from vertical stands and hooks;
 - 3.3.31.3 Hooks shall be designed to fit snugly into the vertical stand slots;
 - 3.3.31.4 Minimum 5 mm steel thickness of a hook and a stand;
 - 3.3.31.5 Hot dip galvanized with smooth surfaces to prevent cable damage;
 - 3.3.31.6 Vertical stand height at least 800mm from manhole base plate till upper element with at least 18 support holes for hooks location;
 - 3.3.31.7 Design load of each cable rack hook is not less than 100 kg;
 - 3.3.31.8 Number of hooks – 2 per vertical stand;
 - 3.3.31.9 Each hook lengths at least: 400 mm or 600 mm;
 - 3.3.31.10 Hook shall be fixed on vertical stand by screw stand to avoid accidental fall;
- 3.3.32 Expected design working life is minimum 50 years;

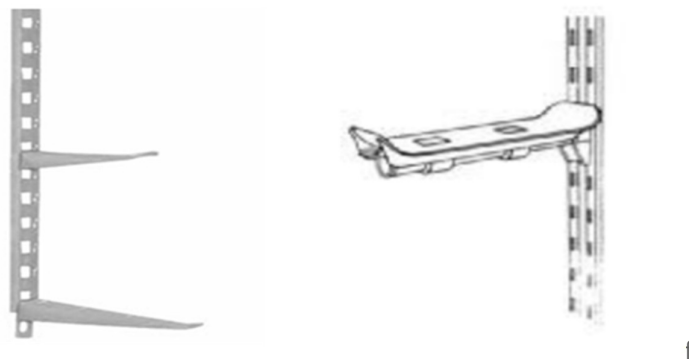

Manhole cable shelf options

- 3.3.33 Manhole Supplier shall include manuals for cable shelf installation in technical documentation of all types of the manholes.

Cable channel

- 3.4.1 Cable channel shall consist of precast modular concrete elements, which shall be installed on site.
- 3.4.2 Precast Cable channels shall be delivered in 3 sizes (please refer to the Figure 16) with lid and implemented as a straight, turned and elevated cable channel element, each of them delivered as:
- 3.4.2.1.1 1 Cable channel section with the length of 1000 mm;
 - 3.4.2.1.2 2 lids made of reinforced concrete with the length of 500 mm;
 - 3.4.2.1.3 2m tar rope of 12mm diameter to be used as a sealing between channel and lid to prevent cracking of lid caused by operation personal walking on Cable channel lids

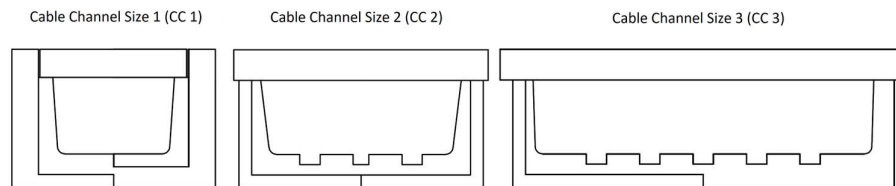

Cable channels configuration.

- 3.4.3 Dimensions of each size of the Cable channel shall be as follows:
- 3.4.3.1 Cable channel Size 1 (CC 1) with outer dimensions of 400 x 275 mm and internal dimensions not less than 240 x 155 mm and integrated lid.
 - 3.4.3.2 Cable channel Size 2 (CC 2) with outer dimensions of 500 x 270 mm and internal dimensions not less than 370 x 155 mm and with top laid lid.
 - 3.4.3.3 Cable channel Size 3 (CC 3) with external dimensions of 800 x 270 mm and internal dimensions not less than 700 x 155 mm and with top laid lid.
- 3.4.4 All types of cable channel elements shall have joint grooves ensuring cable channel longitudinal connection, preventing cable channel horizontal and vertical movements after installation during operation.
- 3.4.5 Cable channel Size 2 and 3 (CC 2 and CC 3) shall allow installation of dividers in the deepening in the bottom (please refer to Figure 16 above and Figure 17 below).

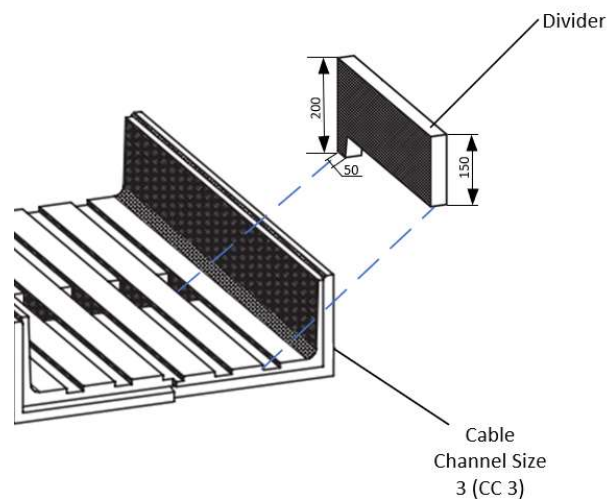

Divider for cable channels CC 2 and CC 3

- 3.4.6 The dimensions of the divider shall be as follows:
- 3.4.6.1 outer dimensions of 500 x 150 (200) x 35 mm (L x H x W)
 - 3.4.6.2 outer dimensions of the fixing leg of the divider 55 x 50 x 35 mm (L x H x W)
- 3.4.7 For each size of the cable channel Supplier shall provide as well turned and elevated cable channel elements:
- 3.4.7.1 Two types of turned elements shall be provided: for implementation of a 15 degree turn and 30 degree turn, as depicted on the Figure 18.



Cable channel elements; 15 degree turn (left) and 30 degree turn (right).

- 3.4.7.2 Two types of elevated elements shall be provided: for implementation of a 15 degree elevation and 30 degree elevation, as depicted on the Figure 19.

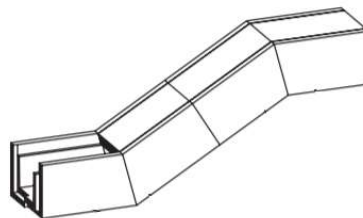

Cable channel elements: 30-degree elevation

Materials

- 3.4.8 The channel and lids shall be Manufactured in concrete C30/37.
- 3.4.9 The lids shall be Manufactured in 500 mm long elements to facilitate their handling and shall be provided with reinforcement, in order to support the bending and impact efforts in their placement and handling. The channel lid shall allow for the transit of people during its useful life without causing it to break.
- 3.4.10 During the Manufacturing process, it shall be guaranteed that both the lid and the channel avoid water infiltration into the channel.
- 3.4.11 Concrete of all precast Cable channels straight, turn and elevation elements shall comply EN 206.
- 3.4.12 Load classes of Cable channel lids shall be as follows:
- 3.4.12.1 Cable channel straight, Cable channel turn, and Cable channel elevation elements shall provide load strength of 10 kN / m² without the possibility of traffic;
- 3.4.13 Cable channel elements surfaces shall be as follows:
- 3.4.13.1 All surfaces of concrete elements must have a uniform texture and be free of pits;
- 3.4.13.2 Cable channel elements shall be produced in reverse state to reach better strength for the structure;
- 3.4.13.3 All surface elements shall be produced without integrated lifting anchors for element lifting and transportation;
- 3.4.13.4 Cable channel lids shall have a non-slippery surface;
- 3.4.13.5 Cable channel elements shall be not coloured.
- 3.4.14 The design working life for the precast concrete channel and their lids is 50 years.

Interfaces

- 3.5.1 For proper integration of Cable system elements which are supplied in different Lots, Supplier of each Lot shall coordinate exact dimensions and materials of the interface elements with Supplier of relevant Lots prior to production:
- 3.5.1.1 Manhole – Multiduct interface:
- 3.5.1.1.1 Multiduct Supplier shall provide Multiduct connectors for Multiduct entering 110mm openings of the Manhole inlets. Connectors shall provide not less than 0,5 bar water resistance.
- 3.5.1.2 Manhole – Duct interface:
- 3.5.1.2.1 Manhole Supplier shall provide Duct connection elements with outer diameter of 110 mm. Connection elements shall provide not less than 0,5 bar water resistance.
- 3.5.1.3 Manhole/Cable channel transition element – Cable channel interface:
- 3.5.1.3.1 Manhole Supplier shall coordinate dimensions of TCC-1 elements (for cable transition from Manhole to Cable channel CC 1) or TCC-2 elements (for cable transition from Manhole to Cable channel CC 2 or CC 3) delivered by set for installation on short side of Manhole.
- 3.5.1.4 Multiduct – Duct interface:
- 3.5.1.4.1 Multiduct and Duct Suppliers shall coordinate to provide Multiduct outer sheath and Duct inner sheath with a smooth surface for convenient Multiduct pulling inside the Duct.
- 3.5.1.5 Cable channel – Duct interface:
- 3.5.1.5.1 Cable channel Supplier shall ensure that Cable channel CC2 has inner dimensions suitable for installation of 3 Ducts with outer diameter of 110 mm and the Cable channel CC3 has inner dimensions suitable for installation of 6 Ducts with outer diameter of 110 mm;
- 3.5.1.5.2 Cable channel Supplier shall ensure that the Cable channel has smooth inner surface for convenient Duct installation.
- 3.5.1.6 Manhole – Manhole drainage duct interface:
- 3.5.1.6.1 Manhole Supplier shall coordinate with the Principal that opening on the base plate is suitable for watertight connection of the drainage pipe.
- 3.5.1.6.2 Drainage opening shall be created on site during Manhole installation for connection with drainage duct.
- 3.5.1.7 Manhole – Multiduct connection element for connection of a Multiduct with the outer diameter 49.5mm +10%/-10%, the Multiduct Supplier shall provide Multiduct

connectors to 110 mm openings for Multiduct entering into Manholes. Connectors shall provide not less than 0,5 bar water resistance.

- 3.5.2 The design of Manhole, cable channel and Transition to cable channel lids shall be analysed as these will be used as a path surface in public areas (at platforms) and maintenance paths (along the track) and shall be safe during operation for passengers and maintenance personnel as well as these shall ensure protection of Ducts and cables from perpetrators.

Cement

- 3.6.1 Cement used for producing the concrete for Manholes and channels shall be produced in accordance with EN 197-1. The Assessment and Verification of Constancy of Performance (AVCP) level of the cement production shall be 1+.
- 3.6.2 Cement minimum strength-grade class shall be $\geq 42,5N$ according to classification in EN 197-1.
- 3.6.3 Sulphur trioxide content of the cement % by mass shall be $\leq 3,5 \%$.

Aggregates

- 3.7.1 Aggregates shall be produced in accordance with EN 12620. The Assessment and Verification of Constancy of Performance (AVCP) level of the aggregate production shall be 2+.

Concrete

- 3.8.1 Concrete produced according to EN 206 and this Specification.
- 3.8.2 Minimum concrete compressive strength class C35/45 for manholes.
Minimum concrete compressive strength class C30/37 for cable channels.
- 3.8.3 Exposure classes for concrete parts where use of de-icing salts is not expected: XC4, XD1, XA1, XF3.
- 3.8.4 Exposure classes for concrete parts where use of de-icing salts is expected: XC4, XD3, XA1, XF4.
- 3.8.5 Max chloride content of 1% (unreinforced Goods).
- 3.8.6 Max chloride content 0.4% (reinforced Goods).
- 3.8.7 Water absorption $\leq 4\%$ by mass.
- 3.8.8 Concrete Resistance to freezing and thawing according to CEN/TS 12390-9 (without de-icing salts), $S56 \leq 0,20 \text{ kg/m}^2$ or $S56 \leq 0,50 \text{ kg/m}^2$ if $S56/S28 \leq 2$.
- 3.8.9 Concrete Resistance to freezing and thawing according to CEN/TS 12390-9 (with de-icing salts), $S56 \leq 0,35 \text{ kg/m}^2$ or $S56 \leq 0,70 \text{ kg/m}^2$ if $S56/S28 \leq 2$.

Reinforcement

- 3.9.1 Steel reinforcement dimensioned and shaped in accordance with EN 1916 & EN 1992-1-1, EN 1916 & EN 1992-1-1. Manufactured according to EN 10080.
- 3.9.2 Welded connection of reinforcing bars may only be used when the weldability of the steel is fully documented.

Security

- 3.10.1.1 In order to reduce physical security risks (vandalism, theft, sabotage) to assets that are critical to railway infrastructure, Cable channel elements and their lids shall be designed and manufactured to ensure protection from perpetrators.
- 3.10.1.2 Cable channel design must provide protection against free access to cables, in other words, the lids mounting method must make it difficult to access the cables without special equipment.

Alkali-silica reactions

- 3.11.1 General information on alkali-silica reactions (ASR)

Manholes and Cable channels in Rail Baltica project are designed with 50-year design life. This requirement demands the highest attention to concrete mix design from Suppliers side. This includes mitigation measures for alkali-silica reactions in all concrete structures. As possible mitigation solutions are varied, and depend on Suppliers' available resources, best mitigation strategy is left for Supplier to implement.

- 3.11.2 There are three acceptable ASR mitigation measures:

- 3.11.2.1 Limiting the alkalinity of the pore solution;
- 3.11.2.2 Use of low alkali cement, stated as Na₂O equivalent amount in cement $\leq 0,60$ %;
- 3.11.2.3 Limiting the alkalinity of concrete itself. Limiting the alkali content in the concrete to 3.0 kg per m³ of concrete of Na₂O equivalent . The amount of alkali is calculated from alkali content in cement + alkali content from additions such as fly ash or slag, alkali content from admixtures and other alkali sources, but not including potential alkali amount from aggregates. If this method is used, aggregate Manufacturer must declare the reactivity of the aggregates as non-reactive to ASTM C1260 – 14, or RILEM TC219-ACS: AAR-0, AR-1.1, AAR-2.4.6.2.2.

- 3.11.3 Previous experience with constituent materials exhibiting no ASR.

4. Design, Sampling, Testing & Acceptance

Design

- 4.1.1 The Supplier shall elaborate detailed technical specifications, drawings with indication of all inner and outer dimensions of each single element.
- 4.1.2 The Supplier shall submit to the Principal detailed technical specification, drawings of Multiducts, Ducts, Manholes, Transition to Cable channel and Cable channels in ".dwg", ".docx", and ".pdf" file formats. All drawings must be approved by Principal before production of the Goods.
- 4.1.3 The Supplier shall provide all static load calculations necessary for application of the cable system elements.
- 4.1.4 All detailed technical specifications, drawings and calculations shall be approved by the Principal before production of the samples for testing.

Testing

- 4.2.1 Multiduct testing shall be performed according to standards EN 61386-1, EN 61386-24.
- 4.2.2 Duct testing shall be performed according to standards EN 61386-1, EN 61386-24.
- 4.2.3 Transition to Cable channel, Cable channels quality assurance systems and testing shall be performed according to standard EN 206-1.
- 4.2.4 Manholes shall be tested according standard EN 1917.
- 4.2.5 Testing facilities and the testing laboratory must be approved by the Principal.
- 4.2.6 Subject to Principal's approval, the Supplier may establish a suitable testing laboratory at the production plant or quarry.
- 4.2.7 All testing must be conducted without undue delay and test results must be promptly tabulated and the Principal must be advised of any failures or trends.
- 4.2.8 Throughout the term of the agreement test and inspection reports shall be provided for Client upon request. Principal reserves right to inspect Manufacturing plant and take part in test procedure to ensure compliance with this specification, related standards and Manufacturing Quality plan.

Production Commencement

- 4.3.1 Commencement production tests shall be carried out in accordance with product related standards:

- 4.3.1.1 Multiduct production shall be performed according to standards EN 61386-1, EN 61386-24.
- 4.3.1.2 Duct production shall be performed according to standards EN 61386-1, EN 61386-24.
- 4.3.1.3 Transition to Cable channel and Cable channels production shall be performed according to standard EN 206-1.
- 4.3.1.4 Manholes shall be produced according standard EN 1917.
- 4.3.2 At least one sample of each element supplied in accordance with chapter 11 of this Technical Specifications shall be produced as a prototype and accepted by the Principal prior to mass production. This shall be done as part of the Factory acceptance test (FAT) procedure.
- 4.3.3 FAT scope shall include checkpoints whether applicable such as, but not limited to:
 - 4.3.3.1 Applicable standards;
 - 4.3.3.2 Reference documents;
 - 4.3.3.3 Testing equipment;
 - 4.3.3.4 Installation, operation, repair and maintenance manual;
 - 4.3.3.5 Installation work quality check and acceptance tests;
 - 4.3.3.6 Labelling/markings;
 - 4.3.3.7 Pressure test requirements;
 - 4.3.3.8 Drain connections;
 - 4.3.3.9 Material of Construction/fillings verified;
 - 4.3.3.10 Controls verified;
 - 4.3.3.11 Welding verified;
 - 4.3.3.12 Overall dimension verified;
 - 4.3.3.13 Assembly each first of Good type;
 - 4.3.3.14 Documentation;
 - 4.3.3.15 Deviations if any;
 - 4.3.3.16 Packaging;
 - 4.3.3.17 Loading, transportation to test area, unloading;
 - 4.3.3.18 Unpackaging;
 - 4.3.3.19 Installation on test area;

- 4.3.3.20 Functional and interface test;
- 4.3.3.21 List of defects;
- 4.3.3.22 Corrective actions are performed, documentation updated.
- 4.3.4 When Goods are accepted by Principal during FAT and the Goods are installed as intended, Supplier design and manufacturing responsibilities of Goods will end, and liability for the operational phase begins.
- 4.3.5 The Civil designer, ENE (Energy) subsystem designer and CCS (Control-Command and Signalling) subsystem designers will perform their own analysis to verify that the supplied Goods and its installation is compliant with the infrastructure, ENE subsystem and CCS systems requirements.

Routine production

- 4.4.1 During routine production, testing must be undertaken according to applicable product specifications.
- 4.4.2 Up to 0,5% of the produced Manholes can be subjected to quality control by Client (for destructive testing).
- 4.4.3 The Supplier shall operate a quality system in accordance with EN ISO 9001 *or an equivalent quality management system conforming to the European certification standards* and considers the requirements of this Technical Specification.
- 4.4.4 All Goods produced and supplied by Supplier must be suitable for recycling at the end of life cycle.

5. Documentation of conformity

- 4.5 Starting supply of Goods, the Supplier must prepare and issue to Client Quality Assurance and Quality Control results in an agreed format, certifying the month's production, itemizing any failures and actions, and attaching a tabulation of inspection and test results.

5.2. Designation, description, marking and labelling of Goods shall be in according with appropriate product standards:

- 5.2.1 for Multiduct : full information according to EN 61386-1 and EN 61386-24;
- 5.2.2 for Duct: full information according to EN 61386-1 and EN 61386-24;
- 5.2.3 for Manholes, Declaration of performance (DoP) and CE marking, according to EN 1917;
- 5.2.4 for Cable channels and Transition to Cable channel according to EN 13369

- 5.3 Goods shall be labelled in accordance with ISO15459 and GS1 standards based on Principal input and coordinated prior routine production.
- 5.4 A Manufacturing Quality Plan must be prepared and be submitted to Principal and Client for approval as a controlled document, including:
- 5.4.1 Factory acceptance test (FAT) before and during manufacturing
- 5.5 .The Supplier must retain all primary quality records in accordance with the statutory requirements, contract conditions and company policy and make these available to Client at all reasonable times. These must include all the requirements of the approved Project Quality Plan.
- 5.6 Supplier shall implement and ensure Quality Assurance during whole life cycle stages of Goods such as, but not limited to:
- 5.6.1 Preparation Manufacturing Quality Plans and design of Goods including:
 - 5.6.1.1 Preparation specification and drawings;
 - 5.6.1.2 Preparation of Manufacturing Quality Plan;
 - 5.6.1.3 Preparation description of the procedure for the Factory acceptance test
 - 5.6.1.4 Preparation of detailed installation, operation, repair and maintenance manuals, installation work quality check and acceptance tests;
 - 5.6.1.5 Preparation of detailed operation manuals with necessary service schedule;
 - 5.6.1.6 Preparation of storage and stockpiling instructions;
 - 5.6.2 Sampling and testing:
 - 5.6.2.1 Production of prototypes and perform I testing of Goods;
 - 5.6.2.2 Certification of Goods according to EU, industry standard and local legislation;
 - 5.6.3 Provision of FAT (Factory acceptance tests) for quality check procedure for acceptance of the Goods production;
 - 5.6.4 Production of Goods;
 - 5.6.5 Delivery of Goods to Client material delivery points in Estonia, Latvia and Lithuania;
 - 5.6.6 Provision of warranty;

6. Documentation

Installation, Storage, Maintenance manuals:

- 6.1.1 The Supplier shall provide to the Client a Manual including the installation, operation, repair and maintenance of Multiducts, Ducts, Manholes, Transition to Cable channel and Cable channels.

- 6.1.2 The Manuals shall be provided in hard and soft copy and must include all drawings and information required to install, repair, and maintain Multiducts, Ducts, Manholes, Transition to Cable channel and Cable channels.
- 6.1.3 Drawings must include sufficient detail to enable the easy identification of all components for the ordering of spares and replacement parts.
- 6.1.4 The manual shall provide full instruction of the installation, geometry tolerances and adjustment of delivered components and inspection and maintenance procedures as applicable.
- 6.1.5 Supplier shall submit storage and stockpiling instructions of Goods considering Rail Baltica project environmental conditions for outdoor storage of Goods.

Drawings

- 6.2.1 For the Multiducts, Ducts, Manholes, Transition to Cable channel and Cable channels, the Supplier shall provide general arrangement and installation drawings in paper and electronic document.
- 6.2.2 Design conformity documentation:
 - 6.2.2.1 Detail design calculations that demonstrate that the Multiducts, Ducts, Manholes, Transition to Cable channel and Cable channels meet all the requirements of this specification;
 - 6.2.2.2 The Supplier shall provide calculations and justifications for the designed lifetime of Multiducts, Ducts, Manholes, Transition to Cable channel and Cable channels.

Language

The Supplier shall ensure the availability of the Documentation in either of the following bilingual versions upon the Clients' request:

- 6.3.1 English and Estonian;
- 6.3.2 English and Latvian;
- 6.3.3 English and Lithuanian;

7. Manufacturing and storing

Manufacturing plants

- 7.1.1 Manufacturing facilities and manufacturing process shall be compliant with ISO 9001 and ISO 14001 standards or equivalent standards conforming to the European certification standards.

Storage and transportation

- 7.2.1 All packaging dimension of finished Goods shall be agreed with Client before transportation to Client material delivery points.
- 7.2.2 Goods shall be delivered in volumes not less than in fully loaded truck, except Supplier proposes the more cost efficient delivery way to the Client.
- 7.2.3 The Supplier shall retain complete responsibility for the quality of the Goods pursuant the terms of the Agreement but un any case at least until they are finally accepted by the Client upon the delivery at the delivery point.
- 7.2.4 All manufactured Goods shall be stored in adequate conditions to ensure their conformity with quality requirements until the Goods are delivered and accepted by the Client. Upon delivery the Goods shall conform to all the requirements under the Technical Specification and Standards.
- 7.2.5 All the damages incurred during storage and delivery shall be assessed to check if the delivered Goods are still conforming with the requirements of the Technical Specification and Standards. If the Goods are not conforming with the requirements herein and have any defects, the respective Goods shall be replaced with Goods conforming with the requirements of the Technical Specification and Standards at the Suppliers cost and in compliance with the terms of the Agreement.
- 7.2.6 The Supplier of Goods shall pack and supply Goods suitable for unloading with front loader.
- 7.2.7 The Supplier of Goods shall supply the Client with special unloading equipment outside the standard market practice for the supply of the particular Goods, if any foreseen by the Supplier
- 7.2.8 Goods that are manufactured according to the Agreement must be stored separately from any other manufacturer's goods. This shall include physical separation as well as separation of stockpile usage record keeping.
- 7.2.9 Goods which must be moved, should never be dragged.