

Design guidelines

# Railway substructure, Part 3 bridges, overpasses, tunnels and similar structures

02-09-2022



Co-financed by the European Union  
Connecting Europe Facility

*The sole responsibility of this publication lies with the author.  
The European Union is not responsible for any use that may be made of the information contained therein.*

## Table of Contents

<b>1.</b>	<b>Technical standards .....</b>	<b>4</b>
1.1.	Eurocodes.....	4
1.2.	EU regulation .....	4
1.3.	UIC leaflets .....	4
1.4.	Other general reference standards .....	4
1.5.	Other reference standards for concrete structures.....	4
1.6.	Other reference standards for steel structures .....	5
<b>2.</b>	<b>General requirements .....</b>	<b>6</b>
2.1.	Safety requirements .....	6
2.1.1.	Basic requirements .....	6
2.1.2.	Overbridge specific requirements .....	6
2.1.3.	Tunnel and cut and cover specific requirements .....	7
2.2.	Security requirements .....	8
2.3.	Operational requirements .....	8
2.4.	Durability requirements.....	9
2.5.	Sustainability requirements .....	9
2.6.	Environmental requirements.....	9
<b>3.</b>	<b>Design basis.....</b>	<b>10</b>
3.1.	Structural Design Requirements .....	10
3.2.	Structures deformations and vibrations .....	10
3.3.	Structures resistance to traffic loads.....	11
3.3.1.	Resistance of new bridges to traffic loads .....	11
3.3.2.	Equivalent vertical loading for new earthworks and earth pressure effects.....	12
3.3.3.	Resistance of new structures over or adjacent to tracks.....	12
3.3.4.	Resistance of existing bridges and earthworks .....	12
3.3.5.	Accidental traffic loads.....	12
3.3.6.	Railway fatigue loads .....	13
3.4.	Structures resistance to other loads .....	13
3.4.1.	Standard Eurocode loads .....	13
3.4.2.	Miscellaneous loads .....	14
3.5.	Combinations of Actions / Limit states.....	15
3.5.1.	Serviceability limit states .....	15
3.5.2.	Ultimate limit states .....	15
3.5.3.	Ultimate fatigue limited state.....	15

3.6.	Elevated Structure Design Features.....	16
3.6.1.	Preferred Bridge types.....	16
3.6.2.	Bridge Skew .....	16
3.6.3.	Walkways, Parapets (edge beams), and Barriers .....	16
3.6.4.	Grounding and Bonding.....	17
3.6.5.	Earth Retaining Structures .....	17
3.6.6.	Waterproofing requirements for tunnel and cut and cover.....	17
3.6.7.	Catenary mast fixings on the bridge deck.....	18
<b>4.</b>	<b>Materials .....</b>	<b>21</b>
4.1.	Concrete.....	21
4.1.1.	Mechanical characteristics:.....	21
4.1.2.	Concrete cover .....	22
4.1.3.	Crack width .....	22
4.2.	Reinforcing Steel.....	22
4.3.	Prestressing steel.....	22
4.4.	Structural Steel .....	22
<b>5.</b>	<b>Maintenance .....</b>	<b>24</b>

# 1. Technical standards

## 1.1. Eurocodes

The mandatory technical standards are:

- Eurocode 0: Basis of structural design,
- Eurocode 1: Actions on structures,
- Eurocode 2: Design of concrete structures,
- Eurocode 3: Design of steel structures,
- Eurocode 4: Design of composite steel and concrete structures,
- Eurocode 7: Geotechnical design,
- Eurocode 8: Design of structures for earthquake resistance, (not applicable).

## 1.2. EU regulation

EU Regulation n° 402/2013 on the CSM for risk assessment is mandatory.

## 1.3. UIC leaflets

UIC leaflets are for information. These leaflets can be used for the design for detailed explanations of requirements and recommendations written in the mandatory standards:

- UIC 774-3: Track/Bridge Interaction – Recommendations for calculations,
- UIC 776-2: Design Requirements for Rail-Bridges based on interaction phenomena between train, track and bridge,
- UIC 776-3: Deformation of bridges,
- UIC 777-2: Structures built over railway lines – Construction requirements in the track zone,
- UIC 779-1 Effect of the slipstream of passing trains on structures adjacent to the track.

## 1.4. Other general reference standards

- EN 1337: Structural bearings (multiple parts),
- EN 1317: Road restraint systems(multiple parts),
- ISO 3864-1:2011: Graphical symbols - Safety colours and safety signs - Part 1: Design principles for safety signs and safety markings.

## 1.5. Other reference standards for concrete structures

Following EN standards are mandatory:

- EN 197-1: Cement: Composition, specification and conformity criteria for common cements,
- EN 206-1: Concrete: Specification, performance, production and conformity,

- EN 12390: Testing hardened concrete,
- EN 10080: Steel for the reinforcement of concrete,
- EN 10138: Prestressing steels,
- EN ISO 17760: Welding - Welding of reinforcing steel,
- ENV 13670: Execution of concrete structures,
- EN 13791: Assessment of in-situ compressive strength in structures and pre-cast concrete components,
- EN ISO 15630: Steel for the reinforcement and prestressing of concrete: Test methods.

## 1.6. Other reference standards for steel structures

Following EN standards are mandatory:

- EN 10025-2: 2004, Hot rolled products of structural steels. Technical delivery conditions for non- alloy structural steels,
- EN 10210-1: 2006, Hot finished structural hollow sections of non-alloy and fine grain steels. Technical delivery requirements,
- EN 10219-1: 2006, Cold formed welded structural hollow sections of non-alloy and fine grain steels. Technical delivery requirements,
- EN ISO 1461: 2009, Hot dip galvanized coatings on fabricated iron and steel articles. Specifications and test methods,
- EN ISO 13918: 2017, Welding. Studs and ceramic ferrules for arc stud welding,
- EN 50122-1: Railway applications — Fixed installations — Electrical safety, earthing and the return circuit Part 1: Protective provisions against electric shock,
- EN ISO 9223: Corrosion of metals and alloys — Corrosivity of atmospheres Classification, determination and estimation,
- ISO 12944: Paints and Varnishes - Corrosion protection of steel structures by protective paint systems Part 2: Classification of Environments,
- EN 10088 Stainless steels —Part 1 and 2: List of stainless steels and Technical delivery conditions for sheet/plate and strip of corrosion resisting steels for general purposes.

## 2. General requirements

### 2.1. Safety requirements

#### 2.1.1. Basic requirements

Risk assessment: Designers shall identify hazards for each element of the design and undertake suitable risk assessments in order to remove/mitigate the risks. Residual, significant risks shall be communicated to all. Principal Contractor shall ensure these risks are considered in the construction and operation of the high-speed railway. An assessment of the risks shall be carried out by the EU Regulation 402/2013 on the common safety method for risk evaluation and assessment.

The check of existing structures and new construction shall be done in accordance with EN 1991-1-7 for required distances to constructions close to railways.

All temporary works must take due consideration of regulations and other statutory health and safety legislation. Any impact on the permanent works shall be clearly communicated.

Maximum pressure variations in any tunnel or underground structure intended to be operated at speeds greater than or equal to 200 km/h shall be under a maximum pressure variation, caused by the passage of a train running at the maximum allowed speed in the tunnel, of 10 kPa during the time taken for the train to pass through the tunnel. For further detail, refer to Infrastructure TSI (INF TSI) chapter 4.2.10.1.

Effect of crosswinds shall be considered per INF TSI chapter 4.2.10.2.

Ballast pick-up shall be prevented per INF TSI chapter 4.2.10.3 on lines with maximum speed greater than or equal to 200 km/h.

In order to limit the damage in case of derailment, all viaduct with length longer than 30m shall be equipped with a guard rails on each track.

All elevated structures shall be designed considering the load of a train in order to prevent structure damages in case of derailment. On elevated structures, buffer stops shall be dynamic buffer stops.

#### 2.1.2. Overbridge specific requirements

Vehicle parapets shall be "moderate to High Containment Level H2 or H3" according to EN 1317 "Road restraint systems" depending on the roadway classification. Detailed requirements are defined in document RBDG-MAN-012 General requirements.

For electrical safety reasons, parapet heights and profiles shall comply with the requirements of the Technical Specification for Interoperability for Energy (ENE TSI) and EN 50122. The minimum electrical protection height shall be 1,80 m above the adjoining paved surface for any span crossing the railway. The length of overhead contact line system protection system shall ensure required protection from any active part of contact line system considering angle of crossing and providing economically optimum solution.

Overhead Contact Line System Protection System design for pedestrian overpasses shall comply with EN 50122 and follow ALG recommendations.

The top of the parapet shall be profiled to deter vandalism and trespass.

Additional measures may be required to deter vandalism. A risk assessment shall be undertaken to determine any required mitigation where there is deemed to be a potential vandalism problem.

All overbridges shall be protected against vehicle impact (Vehicle parapets) and equipped with a vehicle intrusion detector.

Minimum vertical clearances shall be:

- $H_{min} = 6.62\text{m}$  (applicable for overbridge of length on top of the railway inferior to 22.5m and for cases when  $H_{min} = 7.02\text{m}$  cannot be feasibly used)
- $H_{min} = 7.02\text{m}$  (nominal value)

In the case that the System designer is not available the OCS suspension elements shall be fixed by bolts. Structural designer shall prepare a conceptual OCS layout and define areas where drilling for these bolts is possible or forbidden. The drilling and installations of the OCS elements (including bolts) will be in responsibility of the System contractor.

### 2.1.3. Tunnel and cut and cover specific requirements

Fire resistance of tunnel structures shall fulfil the requirements of TSI for Safety in railway tunnels (SRT TSI) chapter 4.2.1.2.

Fire reaction of building material shall fulfil the requirements of SRT TSI chapter 4.2.1.3.

All tunnels shall be equipped with Escape signage per SRT TSI chapter 4.2.1.5.5 and ISO 3864-1:2011.

All tunnels shall be designed with escape walkways:

- Walkways shall be constructed in a single-track tunnel tube on at least one side of the track and in a multiple track tunnel tube on both sides of the tunnel tube.
- The width of the walkway shall be at least 0.8 m.
- The minimum vertical clearance above the walkway shall be 2.25 m.
- The height of the walkway shall be at top-of-rail level or higher.
- Local constrictions caused by obstacles in the escape area shall be avoided. The presence of obstacles shall not reduce the minimum width to less than 0.7 m, and the length of the obstacle shall not exceed 2 m.
- Continuous handrails shall be installed between 0.8 m and 1.1 m above the walkway.

Access for rescue vehicles shall be provided in the area of the tunnel opening.

Minimum vertical clearances shall be:

- $H_{min} = 6,43\text{m}$  for speed = 200km/h;
- $H_{min} = 7,02\text{m}$  for speed > 200km/h.

In the case that the System designer is not available the OCS suspension elements shall be fixed by bolts. The structural designer shall define areas where drilling for these bolts is possible or forbidden. The drilling and installations of the OCS elements (including bolts) will be in responsibility of the System contractor.

For all tunnels of more than 0,5 km in length emergency lighting shall be provided per SRT TSI chapter 4.2.1.5.4.

All tunnels of more than 1 km in length shall include:

- A safe area per SRT TSI chapter 4.2.1.5.1;
- Access per SRT TSI chapter 4.2.1.5.2;
- Communication per SRT TSI chapter 4.2.1.5.3 and chapter 4.2.1.8;
- Firefighting points per SRT TSI chapter 4.2.1.5.7.

## 2.2. Security requirements

For security requirements, design shall prevent unauthorised access to the infrastructure. Refer to RBDG-MAN-12 General requirements.

Design shall prevent unauthorised access to emergency exits and technical rooms.

Where emergency exits are locked for security purposes, it shall always be possible to open them from inside.

## 2.3. Operational requirements

The design speed to be considered is defined in RBDG-MAN-012 General requirements. Additionally for the design of bridges, where it is possible from an operational point a view to consider a future increase in speed, a design speed of up to 300km/h for passenger's trains should be considered during the design phase.

Spatial arrangements shall comply with the requirements of drawings in RBDG-MAN-012 General requirements.

Ballast thickness under sleeper shall be 350 mm minimum.

Tolerances: The structure section shall permit a tolerance on each track position as a minimum of +100 mm horizontally and +50 mm vertically shall be provided to allow for construction tolerances and future maintenance and/or realignment, whilst maintaining structural margins and all minimum clearances. The 50 mm vertical tolerance shall not over-ride the requirements for consideration of upper and lower ballast depths required.

Any proposed solution shall consider the traffic management implications during construction and whole life cost implications for future maintenance.



## 2.4. Durability requirements

Design life shall be in accordance with the requirements written in RBDG-MAN-012 General requirements.

Waterproofing of the bridges decks will be needed. Loose laid waterproofing systems are not permitted. Secondary drainage systems shall be provided below the joints to ensure no leakage can discharge on to the bearing shelf.

Provision shall be made for suitable deck jacking points and access provisions for non-disruptive maintenance.

Expansion joints for ballasted tracks shall ensure that ballast cannot be trapped in the joint opening or moving parts of the joint.

Dissimilar reinforcing steels do not require electrical isolation. However structural steels and metal fixtures and fittings including parapets, signs and anchorages require suitable isolation washers and gaskets to prevent bi-metallic corrosion.

All steel shall be properly protected against corrosion for the design life of the work. Ensure that all materials are adequately corrosion protected to meet the specified environmental conditions. The following provisions shall be fulfilled:

- Take protective measures to prevent corrosion or deleterious effects caused by manufacturing, finishing, transportation, storage and installation of materials.
- Provide full resistance to corrosion for components secured or bolted to each other, including protection against surface damage caused during bolting or securing.
- Ensure that repairs are made to the corrosion protection where damaged by site-cutting of components.
- Minimum requirements for the corrosion protection system for structural steelwork shall be in accordance with the relevant sections of the EN ISO 12944 and consider the specified climatic data in the National appendixes of Eurocode. The environmental category shall be chosen according to the bridge location.
- The first maintenance shall occur at least after 15 years.

Concrete for bridges, overpasses, tunnels and similar structures shall be designed to attain the required chemical resistance to the environment, low permeability, water tightness and water absorption in accordance with the design life.

## 2.5. Sustainability requirements

Sustainable materials shall be incorporated into the design. All proposed construction options shall take full and realistic account of the differences in the costs of maintaining structures of diverse types and materials over their whole life.

Compliance with Sustainability requirements shall not compromise the reliability and durability of the structural elements.

## 2.6. Environmental requirements

Design of all structures shall comply with National Appendix of Eurocode, the EIA performed for the project and RBDG-MAN-027 Environment.

# 3. Design basis

## 3.1. Structural Design Requirements

Structures shall be designed for specified limit states to achieve the objectives of constructability, safety, and serviceability, with the consideration of inspectability, and maintainability, as specified in the European standards otherwise modified here.

Structures shall be designed for the appropriate loadings and shall comply with the HSR structure gauge as per the General requirements (RBDG-MAN-012).

The bridges and elevated superstructures supporting HSRs shall be designed to meet stiffness requirements in order to meet serviceability and comfort requirements for HSR operation.

Permanent and temporary structures including falsework shall be designed in accordance with the clearance requirements. Clearance requirements for falsework are only applicable where the falsework is erected over an operational road or railway.

Design of structures shall consider loads and effects due to erection equipment, construction methods, and sequence of construction.

Seismic Design: As Baltics countries are classified in a low risk area, seismic design shall not be considered.

## 3.2. Structures deformations and vibrations

Vertical acceleration limits for the deck shall be in accordance with the recommended values in EN 1990, A2.4.4.2.1.

Deck twist limits shall be in accordance with EN 1990, A2.4.4.2.2. The recommended values shall be used with the following additional requirements:

- High speed train at full line speed (including dynamic factor): maximum twist  $t_3 = 1.2$ .

Vertical deformation of the deck shall be in accordance with EN 1990, A2.4.4.2.3.

For ballasted track, angular rotation at deck ends shall be limited in accordance with EN 1990, A2.4.4.2.3 (2) and EN 1991-2, 6.5.4.

Angular rotations at the ends of decks in the vicinity of expansion devices, switches and crossings and other track discontinuities, where it is not possible to position these more than 3m from the end of the deck, shall be limited by limiting the maximum deflection of the bridge deck to  $L/1200$ .

Lateral deflections of decks shall be in accordance with EN 1990, A2.4.4.2.4.

Passenger comfort criteria shall be in accordance with EN 1990, A2.4.4.3. The level of comfort required is Very Good (maximum vertical acceleration inside the coach,  $b_v = 1.0 \text{ m/s}^2$ ).

Rail structure interaction (RSI) effects shall be determined in accordance with EN 1991-2. The UIC 774-3R is for information only. In using the modelling procedure set out in EN 1991-2, 6.5.4.4, the following parameters shall be used (Client requirement):

- Displacement of the rail relative to the top of the supporting deck where the rail no longer moves relative to the sleeper,  $u_0 = 2 \text{ mm}$ ,

- The resistance of the sleeper in ballast (unloaded track) of 20 kN/m (modern track maintenance and good track maintenance respectively),
- The resistance of the sleeper in ballast (loaded track) 60 kN/m
- The displacement of the rail relative to the fastening for slab track,  $u_0 = 0.5$  mm.
- The frozen ballast case is applicable to Rail Baltica Project.
- The design assumption made on sequencing of track installation and on time to wait during construction shall be clearly recorded in the design deliverables as these may have significant implications on construction.

### 3.3. Structures resistance to traffic loads

#### 3.3.1. Resistance of new bridges to traffic loads

For resistance of new bridges to traffic loads refer to INF TSI chapter 4.2.7.1.

The requirements of EN 1991-2:2003/AC:2010 and Annex A2 to EN 1990:2002 issued as EN 1990:2002/A1:2005 specified in this section of the INF TSI are to be applied in accordance with the corresponding points in the national annexes to these standards if they exist.

##### 3.3.1.1. *Vertical loads*

Structures shall be designed to support vertical loads in accordance with the following load models, defined in EN 1991-2:2003/AC:2010:

- Load Model 71, as set out in EN 1991-2:2003/AC:2010 point 6.3.2 (2)P;
- Load Model SW/2, as set out in EN 1991-2:2003/AC:2010 point 6.3.3 (2);
- In addition, for continuous bridges, Load Model SW/0, as set out in EN 1991-2:2003/AC:2010 point 6.3.3 (3)P.

The load models shall be multiplied by the factor alpha ( $\alpha$ ) as set out in EN 1991-2:2003/AC:2010 points 6.3.2 (3)P and 6.3.3 (5)P. **According to the EC rules / UIC 702 leaflet for heavy freight traffic transeuropean corridors, alpha ( $\alpha$ )=1.33 shall be considered.**

For light freight traffic portions (see general requirements (RBDG-MAN-012)), consideration of Load Model SW/2 is not required and alpha ( $\alpha$ )=1.0 shall be considered.

##### 3.3.1.2. *Allowance for dynamic effects of vertical loads*

The load effects from the Load Model 71 and Load Model SW/0 shall be enhanced by the dynamic factor phi ( $\Phi$ ) as set out in EN 1991-2:2003/AC:2010 points 6.4.3 (1)P and 6.4.5.2 (2).

For bridges for speeds over 200 km/h where EN 1991-2:2003/AC:2010 paragraph 6.4.4 requires a dynamic analysis to be carried out the structure shall additionally be designed for HSLM defined in EN 1991-2:2003/AC:2010 paragraphs 6.4.6.1.1 (3) to (6) inclusive. Standard track maintenance is recommended to determine the dynamic factor. For damping the recommended values give in the EN 1991-2 6.4.6.3.1 – “Structural damping” are applicable. For vertical frequency analysis, 2 conditions shall be investigated:

- Condition chapter 1 – a lower bound estimate of stiffness and upper bound estimate of mass
- Condition chapter 2 – a lower bound estimate of stiffness and lower bound estimate of mass

### 3.3.1.3. *Centrifugal forces*

Where the track on a bridge is curved over the whole or part of the length of the bridge, the centrifugal force shall be considered in the design of structures as set out in EN 1991-2:2003/AC:2010 paragraphs 6.5.1 (2), (4)P and (7).

### 3.3.1.4. *Nosing forces*

The nosing force shall be considered in the design of structures as set out in EN 1991-2:2003/AC:2010 point 6.5.2.

### 3.3.1.5. *Actions due to traction and braking (longitudinal loads)*

Traction and braking forces shall be considered in the design of structures as set out in EN 1991-2:2003/AC:2010 paragraphs 6.5.3 (2)P, (4), (5), (6) and (7)P.

According to EN 1991-2, 6.5.3 (9)P, braking and acceleration shall be considered on both tracks in the same direction.

For braking loads, the design shall consider:

1. full load one track,
2. half the full load on the second track.

## 3.3.2. Equivalent vertical loading for new earthworks and earth pressure effects

For equivalent vertical loading for new earthworks and earth pressure effects imposed on new structures refer to INF TSI chapter 4.2.7.2:

- Earthworks shall be designed, and earth pressure effects shall be specified considering the vertical loads produced by the Load Model 71, as set out in EN 1991-2:2003/AC:2010 paragraph 6.3.2(2).
- The equivalent vertical loading shall be multiplied by the factor alpha (a) as set out in EN 1991-2:2003/AC:2010 paragraph 6.3.2 (3)P.

## 3.3.3. Resistance of new structures over or adjacent to tracks

For resistance of new structures over or adjacent to tracks refer to INF TSI chapter 4.2.7.3:

- Aerodynamic actions from passing trains shall be considered as set out in EN 1991-2:2003/AC:2010 paragraphs 6.6.2 to 6.6.6 inclusive.

## 3.3.4. Resistance of existing bridges and earthworks

For resistance of existing bridges and earthworks to traffic loads refer to INF TSI chapter 4.2.7.4.

## 3.3.5. Accidental traffic loads

For derailment on railway bridges please refer to EN 1991-2 chapter 6.7.

For Derailment under or adjacent to a structure and other actions for Accidental Design Situations please refer to EN 1991-1-7.

### 3.3.6. Railway fatigue loads

Railway fatigue loads are defined in appendix D of EN 1991-2.

## 3.4. Structures resistance to other loads

### 3.4.1. Standard Eurocode loads

National appendix shall be used for the design of the structures.

Actions to be used in design may be obtained from the relevant parts of EN 1991. The relevant parts of EN1991 for use in design include:

- EN 1991-1.1 Densities, self-weight and imposed loads
- EN 1991-1. 2 Fire actions
- EN 1991-1.3 Snow loads
- EN 1991-1.4 Wind loads
- EN 1991-1.5 Thermal actions
- EN 1991-1.6 Actions during execution
- EN 1991-1.7 Accidental actions due to impact and explosions
- EN 1991-2 Traffic loads on bridges
- EN 1991-3 Actions induced by cranes and other machinery
- EN 1991-4 Actions in silos and tanks

#### 3.4.1.1. *Permanent loads*

Dead loads (DC, DW): Refer to EN 1991-1-1 for design guidance and actions for the structural design of buildings and civil engineering works, including the following aspects densities of construction materials and stored materials and self-weight of construction elements. For specific component refer to list below:

- Ballast (including sleeper) 20 kN/m<sup>3</sup>
- 2 rails per track + fastening 1.5 kN/m/track
- 1 handrail on each side (2 units) 0.7kN/linear meter/unit

For Downdrag force on pile (DD), Earth pressure (EV, EH), Earth surcharge (ES), Earth settlement effects (SE) refer to EN1997: Geotechnical design.

Differential settlements/movements of the structure due to soil subsidence shall be classified as a permanent action for the design of structures, recommended value to be considered for the structural design is 10mm.

Uniform settlement shall be maximum 40mm with maximum settlement of 10mm per year after completion of construction and installation of all superimposed permanent loads including the trackwork.

Creep effects (CR), Shrinkage effects (SH), Secondary forces from prestressing (PS) shall be considered per EN 1992.

Water loads (WA). For major water crossing water action shall be considered.

Ballast removed on one track shall be considered as a possible maintenance load case.

As defined in chapter 5.2.3 of EN 1991-1-1, the ballast density variation and ballast thickness variation for permanent load shall be considered in calculations.

As defined in chapter 6.4.6.3.2(2)P of EN 1991-2 for dynamic analysis, two specific cases for the mass of the structure including ballast and track shall be considered:

- a lower bound estimate of mass to predict maximum deck accelerations using the minimum likely dry clean density and minimum thickness of ballast;
- an upper bound estimate of mass to predict the lowest speeds at which resonant effects are likely to occur using the maximum saturated density of dirty ballast with allowance for future track lifts.

### 3.4.1.2. *Transient loads*

Live loads LL (other than railways traffic) Traffic actions on bridge are defined in EN 1991-2

Action on barriers (HB) horizontal forces are given in EN 1991 Section 6. Annex B

Wind loads (WS, WL): Wind load according to EN 1991-1-4. (return period of 50 years)

Snow loads (SW): Snow load are defined in Appendix 2 of EN 1991-1-6. (return period of 50 years)

Ice loads (IC): Ice load are defined in chapter 4.9 of EN 1991-1-6.

Thermal loads (TU, TG) Thermal actions are defined in EN 1991-1-5.

Seismic loads Earthquake according to EN 1998-2 (return period of 475 years). As stated in chapter 3.1., no seismic design shall be considered.

Collision loads (CL): Vehicle collision loads as defined in EN 1991-1-7 chapter 4.3.1 and chapter 4.3.2; Forces due to vehicle impact are specified in EN 1991-1-7 and EN 1991-2.

## 3.4.2. Miscellaneous loads

### 3.4.2.1. *Loads for Design of the Surrounding Area of the Embedded Sleeves of Overhead Contact System Pole Foundation*

Action on the OCS pole has to be determined by the System designer.

In the case that the System designer is not available the following values for dead load only (to be combined with wind slipstream) shall be used as a reference.

- Vertical load = 140 kN
- Shear force = 8 kN
- Moment = 55 kNm

### 3.4.2.2. *Loads for Design of the suspension elements of Overhead Contact System in overbridges and tunnels*

Action on the OCS equipment as described in sections 2.1.2 and 2.1.3 has to be determined by the System designer.

In the case that the System designer is not available the following values for dead load of catenary suspensions only (to be combined with wind slipstream where required) shall be used as a reference

- Vertical load = 20 kN
- Shear force = 6 kN
- Moment = 40 kNm

For suspension of overhead wiring the following values for dead load of feeder wire suspensions only (to be combined with wind slipstream where required) shall be used as a reference

- Vertical load = 8 kN
- Shear force = 4 kN
- Moment = 25 kNm

## 3.5. Combinations of Actions / Limit states

The application of loads for railway bridge is defined in EN 1991-2 chapter 6.8. Refer to EN 1990 Annex A2 Combination rules for railway bridges. Recommended values are applicable to Rail Baltica project.

### 3.5.1. Serviceability limit states

Refer to EN 1990 chapter 6.5 – for the definition of Serviceability limit states.

### 3.5.2. Ultimate limit states

Refer to EN 1990 chapter 6.4 – for the definition of Ultimate limit states.

### 3.5.3. Ultimate fatigue limited state

Refer to EN 1991-2 chapter 6.9 – for the Traffic loads for fatigue and Annex D Basis for the fatigue assessment of railway for Fatigue checks.

Fatigue analysis shall be based on following parameters:

- Annual traffic volume and design life of the bridge =  $2.5 \text{ E}+07$  [T/year/track]
- Type of traffic = ECMIX
- Number of tracks = 2

The assessment of fatigue, which usually involves checking variations in amplitude constraints, shall be conducted in accordance with:

- EN 1992-2 for concrete structures;
- EN 1993-1-9 for steel structures;

- EN 1994-2 for composite steel/concrete structures.

## 3.6. Elevated Structure Design Features

### 3.6.1. Preferred Bridge types

Because of the considerable number of structures along the line, particular care shall be taken in the design to reduce maintenance requirements. The following requirements shall apply:

- Integral bridges without bearings and joints are preferred,
- Continuous decks are preferred over multiple single span deck to avoid structural joints maintenance,
- Reinforced or prestressed concrete structures are preferred over steel structures (except for cases where steel structures are clearly requested by the Client and already proven by the preliminary design or as a result of heritage protection requirements)
- Otherwise, the Designer shall justify in writing the use of steel structures and composites structures, demonstrating the benefits of any new steel structure.

For Viaduct with spans above 50m, preference for type is prestressed concrete single box girders carrying two tracks for main line structures. Box girders can be precast, precast segmental, or cast in-place, cast-in-place span by span or other similar types of construction.

For bridge spans up to 20m, solid slab cross-sections are preferred.

For bridges spans between 20m and 50m, wide single or double T-beams are preferred.

Massive concrete piers/columns are recommended.

### 3.6.2. Bridge Skew

The preferred angle of crossing and bridge structure relative to the centreline of track is 90 degrees. In cases where a 90-degree crossing cannot be constructed, recommended skew limit is 65 degrees.

Special structure shall be designed for skew under 65 degrees. The skew of bearing line versus the deck axis is recommended not to exceed 30-degrees for special structures.

### 3.6.3. Walkways, Parapets (edge beams), and Barriers

Walkways shall be precast or cast in-place concrete. The walkway shall be a non-slip material.

Continuous and plain concrete parapet (edge beam) is recommended.

Parapets (edge beams) shall be provided along edges of elevated structures, bridges, and HSR grade separation structures. Parapets (edge beams) shall be designed for wind loads, slipstream effects. Specific parapets (edge beams) shall be designed to accommodate installation of noise barriers.

The height of noise barriers shall be determined based on results from the noise attenuation study. The sound wall and its connection to the structure shall be capable of resisting the slipstream effects from passing trains and the



wind load. No gap shall be permitted between the bottom of sound wall and the structure deck, nor any vertical gaps between the sound wall panels.

For the visual design of the Noise Barriers please refer to RBDG-MAN-031F.

Other barriers (wind, visual, etc) should be designed according to a specific study.

### 3.6.4. Grounding and Bonding

All metallic items on structures crossing over, under or immediately adjacent to the electrified tracks shall be bonded either directly or indirectly to a static wire and/or to a trackside grounding plate for personnel safety. More details on general grounding system are defined in RBDG-MAN-018, chapter 3.7 Earthing and bonding system.

The structural steel elements, steel reinforcement in the structure elements, including the viaduct parapets, shall be interconnected electrically and shall be electrically continuous.

The railway structures, such as bridges, viaducts, overbridges and eoduct will have their own earthing and bonding system. The earthing and bonding principle consists in the interconnection of all the metallic elements such as the reinforcements of the piers, the walls and the abutments. The electrical continuity shall be done connecting all the reinforcements and bonded with the foundation's reinforcement which shall be connected to the ground using earth conductor of fifty square millimeters (50 mm<sup>2</sup>) minimum cross-section area.

The earth conductor shall be connected to earth rod installed in an earth manhole pit.

Earthing terminals for the connection of the reinforcement of the structures to the rails/poles shall be designed by structural designer.

The connections of structural earthbars to rails/poles will be designed by System designer.

The ground resistance, measured at the grounding plate prior to any further connections as detailed below, shall be 25 ohms or less.

The required ground resistance of 25 ohms shall be achieved, if necessary by connecting the grounding plate(s) directly to buried ground electrodes.

### 3.6.5. Earth Retaining Structures

Earth retaining structures shall be designed to lateral earth pressures in accordance with the Geotechnical studies.

Top of retaining walls, including fill, cut, and trench walls, shall be at least 0.50m above finish grade

Wall heights may be higher as required for flood elevation and intrusion protection requirements.

Maximum distance between expansion joints in retaining walls shall be 25 m.

Maximum distance between construction/ contraction joints shall be 10m.

### 3.6.6. Waterproofing requirements for tunnel and cut and cover

#### 3.6.6.1. *Cut and Cover*

Water tightness of the concrete structure shall be achieved by the combination of the following measures:

1. Crack Widths – control of crack widths in accordance with EN 1992-1-1 or EN 1992-3

2. Construction – minimizing construction joints in the external / exposed slabs
3. Waterproof Joints – between adjoining structures
4. Water-bars and water stop joints – for the diaphragm wall construction, this will include a single water bar or water stop at each panel joint
5. Waterproofing Membrane – application of a waterproofing system to the external surface of the base slab, roof slabs and partial wall as required

### 3.6.6.2. *Tunnel*

Water tightness systems shall be carefully selected and designed to satisfy the following main requirements:

- Suitability to achieve the required class of water tightness
- Suitability for the type of supports
- Resistant to shrinkage, elongation and all deformations caused by different actions (load, high and low temperatures, etc.)
- Safely resist the acting water pressure
- Resistant to hydrocarbons, sulfates, cement, calcium carbonate, chlorides and any other chemicals that might exist in the ground water and adjacent ground materials
- Compatibility with filling materials, residues of curing compounds (if used), bitumen membranes, etc.
- In case of waterproofing membrane, specification of welding and overlapping between the membrane sheeting
- Durable for the whole lifetime of the project

For the different structural parts of the permanent structures, a specific degree of water tightness as well as a maximum daily leakage rate into the completed tunnels shall be defined.

For conventional tunnels, in case the groundwater drainage is not allowed, a full round waterproofing system without drainage pipes shall be foreseen (for example: tunnel underneath rivers).

## 3.6.7. Overhead contact line pole fixings on the bridge deck

### 3.6.7.1. *Short bridges (length less than 25 m)*

Overhead contact line poles shall not be placed on short bridges, if all following conditions are met:

1. The railway bridge is not located at a distance inferior to 300 m from any turnout of a station, cross-over of junction or other track element that could impact the location of overhead contact line poles;
2. The railway bridge is isolated from other constraints in a tensioning length of 1200 m, meaning:
  - a) No other railway bridges are located at a distance inferior to 600 m;

- b) No road overbridges incl. tunnel-type structures such as ecoducts are located at a distance inferior to 600 m, except if all these structures provide possibility to implement OCS (overhead contact line system) without constraints (either by allowing OCS free passage or by allowing fixing of OCS support(s) onto the structures;
- c) No railway tunnels are located at a distance inferior to 600 m;
- d) No traction substations are located at a distance inferior to 600 m.

3. The railway bridge is not located in a track curve with the radius inferior to 2000 m.

In case if at least one of above listed conditions is not met, overhead contact line poles shall be placed on short bridges according to requirements set in section 3.6.7.2 for medium bridges.

### 3.6.7.2. *Medium bridges (length between 25m and 200m)*

Overhead contact line fixings shall be integrated in the bridge deck design. Detailed design of fixing interfaces shall be prepared and submitted by the structural engineer using the foot plate dimensions in section 3.6.7.4.

The locations of OCS poles and anchoring foundations shall be determined by the System designer.

In the case that the System designer is not available the structural designer shall prepare a conceptual OCS layout taking into account the conditions nearby the bridge as described in section 3.6.7.1 (points 1, 2 and 3). For this conceptual OCS layout the OCS span length as defined in RBDG-MAN-019 shall be:

- minimum span length = 30 m;
- maximum span length = 54 m.

If anchors for tensioning devices or mid-point shall be needed the anchor foundation shall be located 8.5 m from the closest OCS pole location.

The proposed conceptual OCS layout shall be approved by RB Rail AS.

Drillings through the bridge deck shall not be allowed.

### 3.6.7.3. *Long bridges (length more than 200m)*

Overhead contact line fixings shall be integrated in the bridge deck design.

The locations of OCS poles and anchoring foundations shall be determined by the System designer.

In the case that the System designer is not available the structural designer shall prepare a conceptual OCS layout taking into account the conditions nearby the bridge as described in section 3.6.7.1 (points 1, 2 and 3). For this conceptual OCS layout the OCS span length as defined in RBDG-MAN-019 shall be:

- minimum span length = 30 m;
- maximum span length = 54 m.

If anchors for tensioning devices or mid-point shall be needed the anchor foundation shall be located 8.5 m from the closest OCS pole location.

It is the structural designer's task to verify if the distances are enough on a case-by-case basis or additional optimization is necessary –approval by RB Rail AS.

Overhead contact line system shall be adjusted to the OCS fixing locations on the bridge deck on embankments before and after approaching structure. Detailed design of fixing interfaces shall be prepared and submitted by the structural engineer.

Drillings through the bridge deck shall not be allowed.

### 3.6.7.4. Standard OCS foundations on bridges

It is required to use a universal solution for the civil design of bridges along the RB network.

OCS poles on bridges shall be only H-Type mast type as universal solution. This mast type is usable in all OCS technologies.

The anchoring bolts are integrated in the civil structure. The structural engineer shall be designed these bolts in its bridge design.

The dimensions of anchor bolt (mast plate) are demonstrated in the following figures:

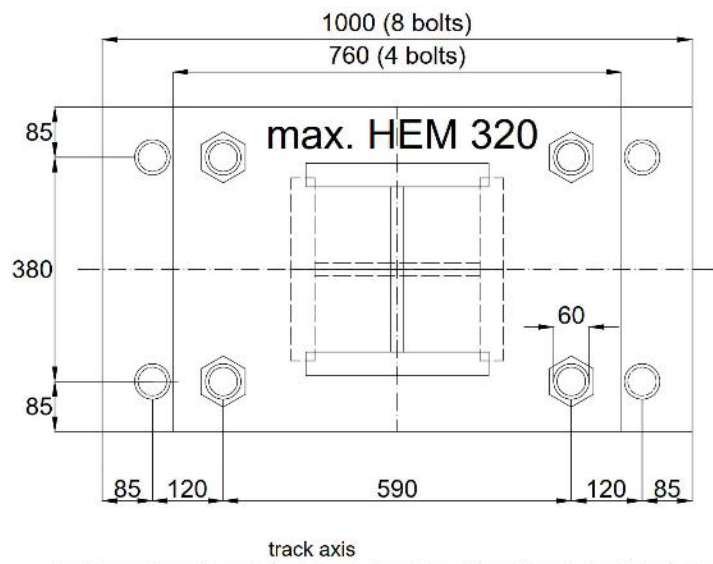

1. DIMENSION OF THE MAST-PLATE

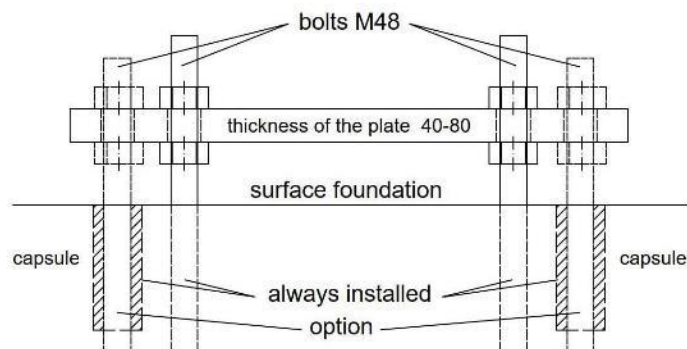

2. SIDE VIEW OF THE MAST-PLATE

For anchoring of ropes of the anchoring poles shall be used also a universal solution as shown in the following figure.

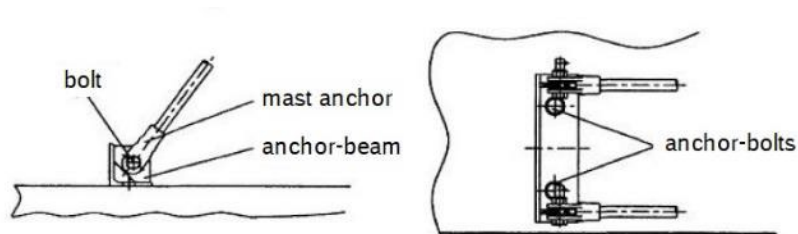

3. ANCHOR FOUNDATION

## 4. Materials

In all cases minimum value is given. Justification has to be provided for higher values used.

### 4.1. Concrete

#### 4.1.1. Mechanical characteristics:

The structural class of bridges S5 according to EN-1990 durability classes.

The concrete minimum strength requirements for railway structures are:

- For span (superstructure):  $f'c$  28 days tested on cylinder = 45 MPa;

- For pier cap, pier:  $f'c$  28 days tested on cylinder = 35 MPa;
- For foundation:  $f'c$  28 days tested on cylinder = 30 MPa.

The concrete minimum strength requirements for non-railway structures are:

- For pier, pier cap, span (superstructure):  $f'c$  28 days tested on cylinder = 35 MPa;
- For foundation:  $f'c$  28 days tested on cylinder = 30 MPa.

## 4.1.2. Concrete cover

Exposure classes are classified according to EN 1992-1-1 table 4.1. Project requirement for exposure classes are defined in RBDG-MAN-012 general requirements.

In order to transmit bond forces safely and to ensure adequate compaction, the minimum cover shall not be less than  $c_{min,b}$  as given in EN 1992-1-1 table 4.2.

In order to achieve the required working life of the structure (100 years), it is necessary to re-evaluate the structural class in accordance with EN 1992-1-1 table 4.3 N.

The recommended values of  $c_{min,dur}$  are given in the EN 1992-1-1 tables 4.4N and 4.5N.

## 4.1.3. Crack width

A limiting calculated crack width,  $w_{max}$ , considering the proposed function and nature of the structure and the costs of limiting cracking, shall be established. The characteristic crack width,  $w_k$ , is calculated according to EN 1992-1-1 chapter 7.3.4.

The value of  $w_{max}$  shall be taken for relevant exposure classes are given in EN 1992-1-1 Table 7.1N.

## 4.2. Reinforcing Steel

The specified yield strength of the steel reinforcement is  $f_{yk} = 500$  MPa.

Total elongation at maximum force  $\epsilon_{uk} \geq 5\%$ .

The modulus of elasticity of passive reinforcement  $E_s$  is taken as 200 000MPa.

## 4.3. Prestressing steel

Low relaxation strands shall be used:

The specified nominal ultimate strength of the prestressing steel is  $f_{pk} = 1860$  MPa or  $f_{pk} = 1770$  MPa.

## 4.4. Structural Steel

The structural steel is S355. The density of steel shall be equal to 78.5 kN/m<sup>3</sup>.

A suitable grade of steel shall be selected to ensure sufficient reliability of each component against brittle fracture, taking account of the following factors:

- Level of resilience of steel;
- Shape of the part;
- Thickness of the part;
- Suitable assumptions for imperfections such as cracks;
- Minimum operating temperature;
- Strain rate.

The level of resilience of the steel in relation to the resilience required by reference to fracture mechanics and the characteristics of resilient material are detailed in EN 10025.

The steel grade and the minimum thickness of the steel parts to be used shall be determined in accordance with EN 1993-1-10 chapter 2.

## 5. Maintenance

Structure design shall consider the implications of inspection and maintenance in a fully operational environment.

The overbridge design shall minimise maintenance requirements:

- Painted steel overbridges shall not be permitted over RB tracks due to the requirement for ongoing maintenance of the protective paint system.
- The overbridge design shall identify and justify by risk assessment any hidden critical elements which cannot be inspected visually.
- In order to minimise maintenance requirements adjacent to the high-speed rail line, overbridges should be designed as continuous with no bearings over intermediate supports unless exceptional circumstances exist. Overbridges should be of fully integral construction where possible.

Permanent access for arm's length inspection and maintenance shall be provided for the following elements:

- Drainage
- Expansion joints
- Abutment bearings
- Parapets
- Electrical bonds

When needed structures should have access staircases to allow maintenance and inspection. Specific requirements should follow national technical regulations.

The design shall identify a practical method of inspection for the following elements which may require temporary access equipment:

- Pier bearings
- Deck soffit
- Telecommunication and power supply cables
- Bearings

Drainage systems shall not be cast in to the structure such that access for maintenance is compromised. Down pipes shall not be cast in to piers or abutments but may be screened by removable panels or by careful detailing.

All drain pipes, gullies and hoppers shall be provided with means of rodding or water jetting.

Provision shall be made for suitable jacking points and access provision for non-disruptive maintenance.

Inspection and maintenance steel bridge: Construction details of steel bridges shall facilitate maintenance and inspection so that inspection and maintenance can be performed without interruption of train operation. Steel box girders and box beams shall have access hatches to allow maintenance and inspection of the member.

Maintenance and Inspection of Concrete Structures: Inspection and maintenance hatches shall be provided into each closed girder. These hatches may be through the girder soffits or in combination with openings between adjacent girder diaphragms. The minimum headroom inside of typical box girders shall be 1,2m. Minimum clearance from girder ends to bearings and from abutment backwalls to bearings shall be 0.75m to allow for access.



Bearings shall be easily accessible for inspection. They shall be adjustable and replaceable at any time during the life of the structure without disrupting train normal operations.

If a pier is not accessible from the ground beneath, such as for a bridge crossing a river, a 0.80m\*0.80m access opening with steel grating shall be provided in the bottom slab of decks so that the pier top can be reached from the inside of the box girder.

In the design of bridges, the vertical load of the maintenance gantry on the deck overhang shall be taken into consideration. The maintenance gantry shall be represented by a load to be defined by the provider. If possible, inspections devices shall be considered as maintenance overhead gantry. If the location of the catenary mast is conflicting with the maintenance proposed method (maintenance overhead catwalks installed on the structure itself for instance), an alternative solution shall be developed.

Necessary permanent installations as per identified inspection method shall be proposed in the Design. The designer shall detail the maintenance method and indicate in the drawings the required dimension for maintenance equipment (embankment size and location for instance). The maintenance methods shall be proposed to the Client and the use of different maintenance equipment shall be limited.

Where no other access exists, a light access road located in the vicinity of the structure (each side for viaduct and tunnel) shall be provided to enable future inspection and maintenance. Detailed requirements are defined in the document RBDG-MAN-012 general requirements for light access road.