

Main Track Part 1

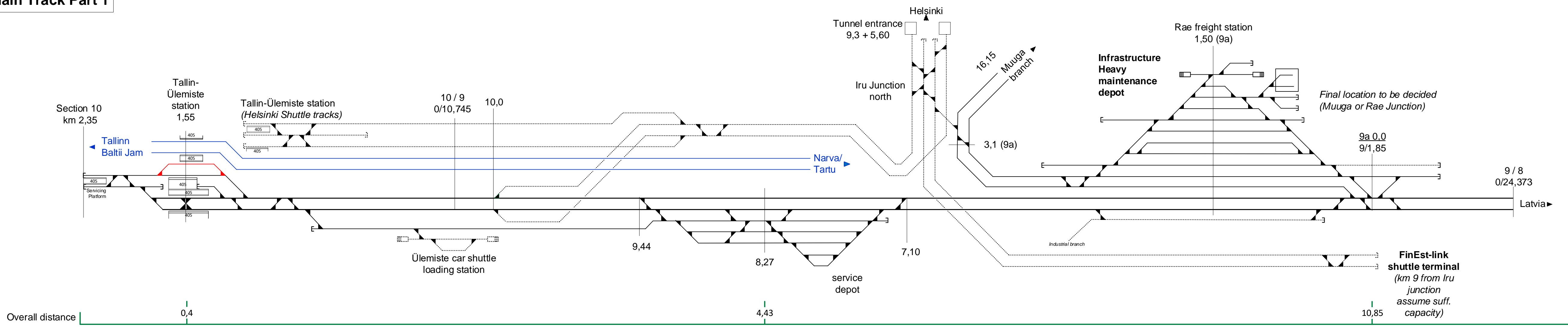

FinEst tunnel

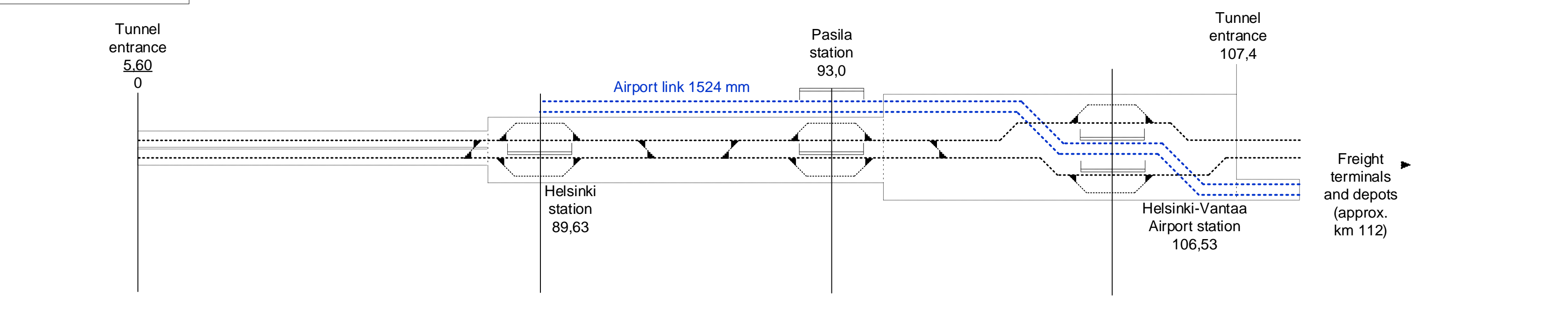

Legend

- Track Layout in 2026
- Track Layout in 2036-46
- Track Layout in 2056
- - - Interfaces to local facilities/ other projects
- Track 1520 mm
- Dual gauge track 1435/1520 mm
- ..... Optional track
- Passenger platform (405 m / 210 m)
- 6,10 Turnout with indication of line- km
- Rapla station 11,46 Operational point with indication of line-km
- 7 / 6 0/18,696 Planning section border with change of line-km
- 92,33 7,00 change of line-km
- 230 Speed on specific turnout in diverging direction

Muuga Freight Terminal

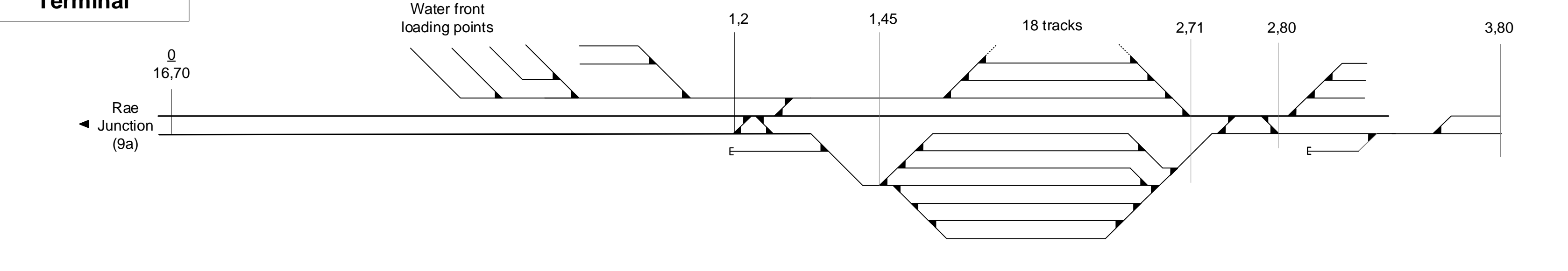

Main Track Part 2

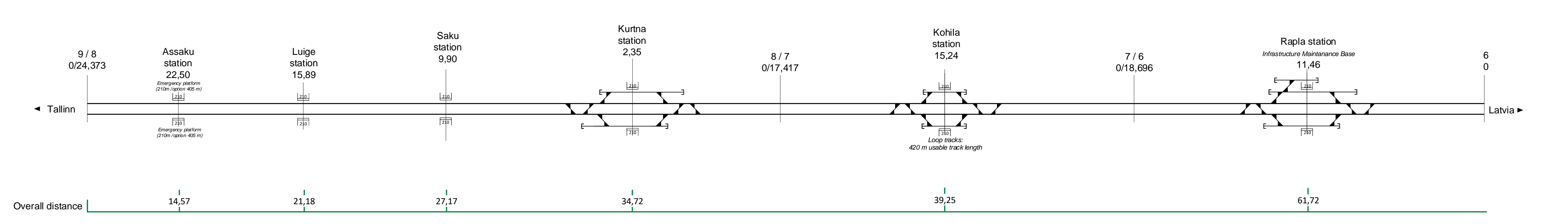

Main Track Part 3

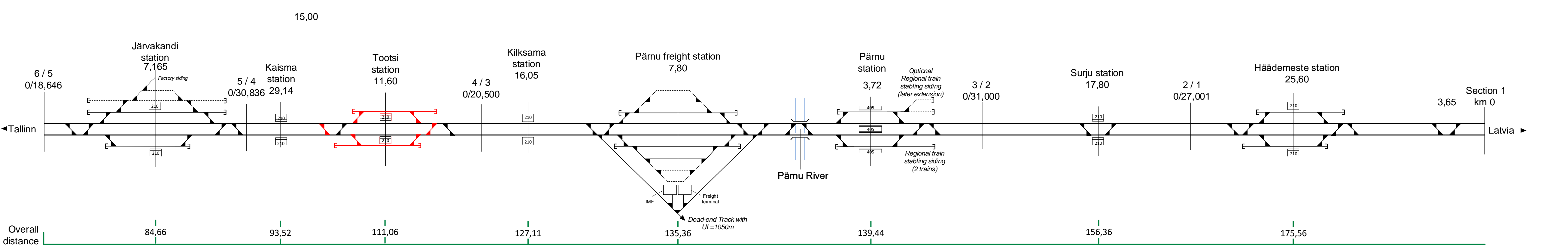

Main Track Part 4

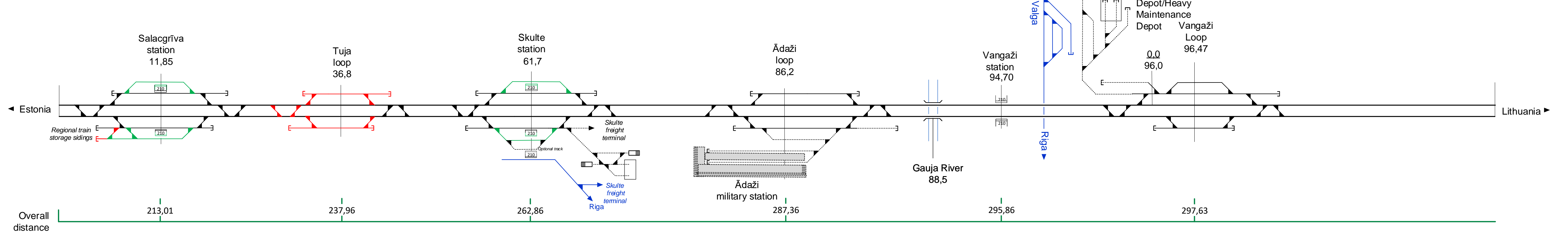

Main Track Part 5

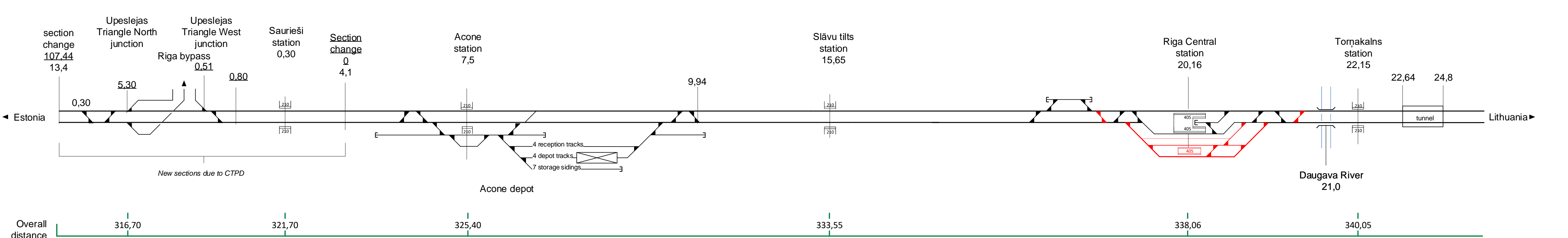

Riga Bypass

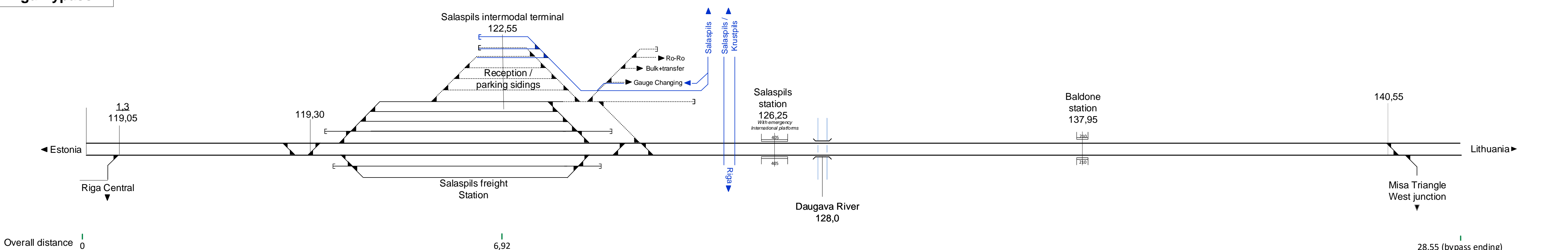

**Main Track Part 6**

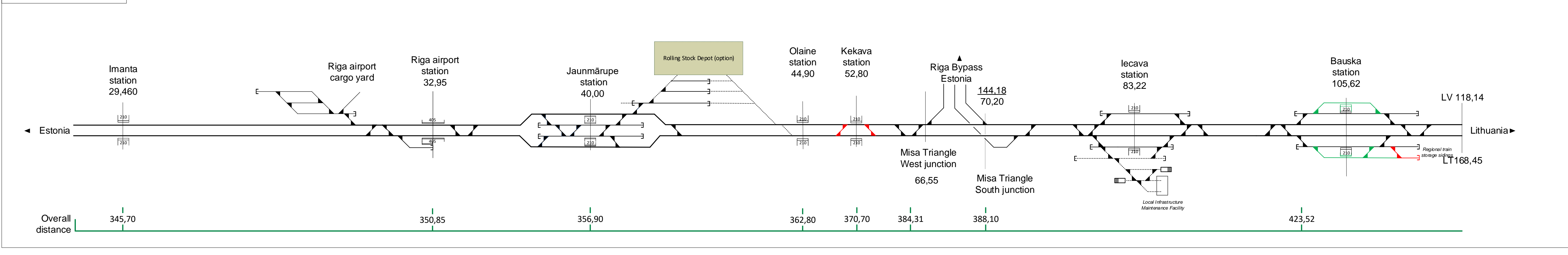

**Main Track Part 7**

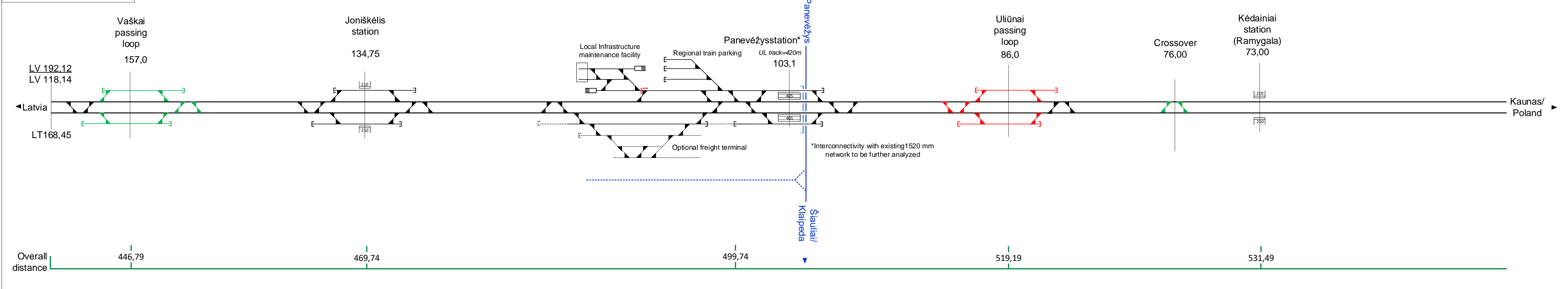

**Main Track Part 8**

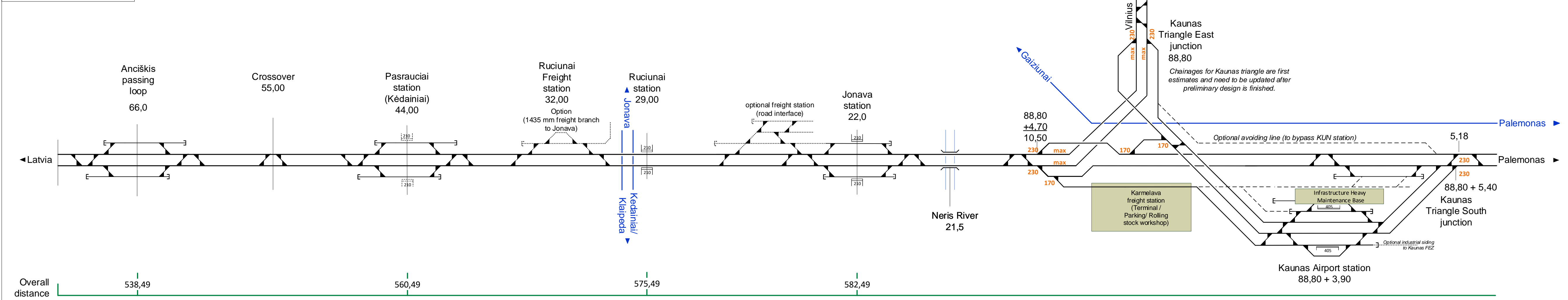

**Main Track Part 9**

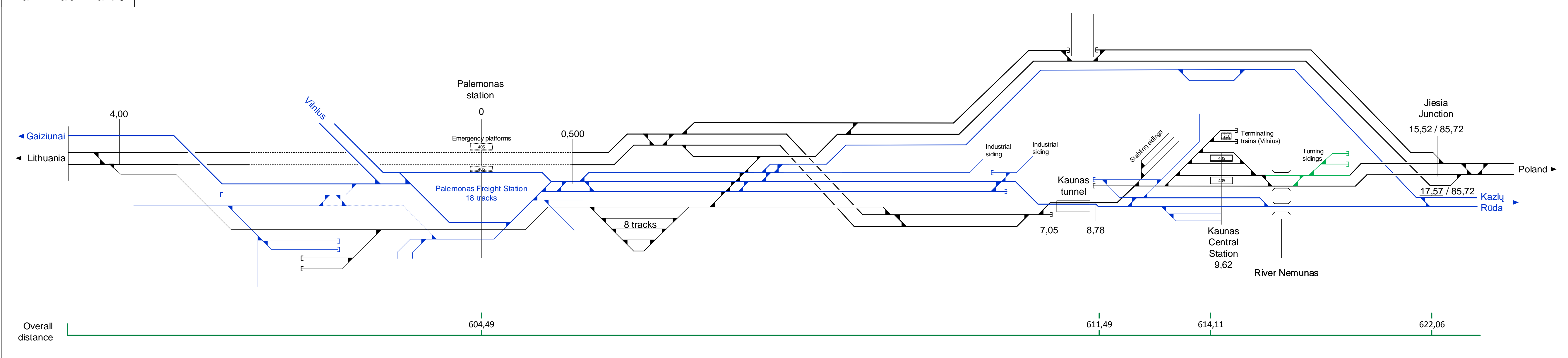

**Main Track Part 10**

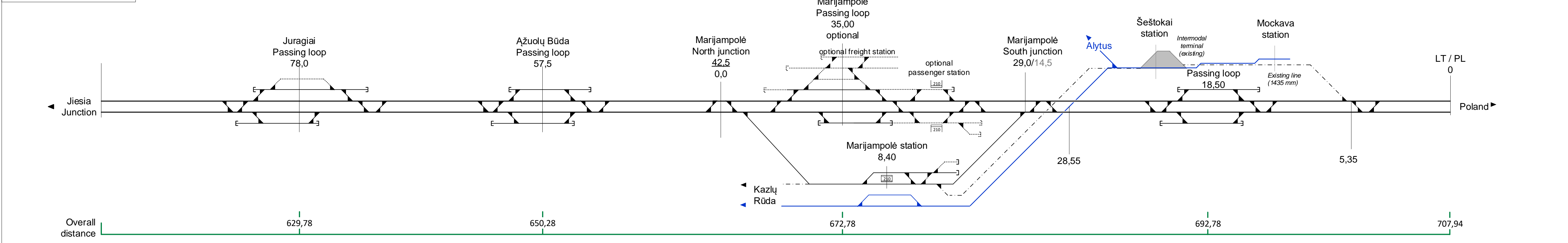

**Poland (for informative purpose only)**

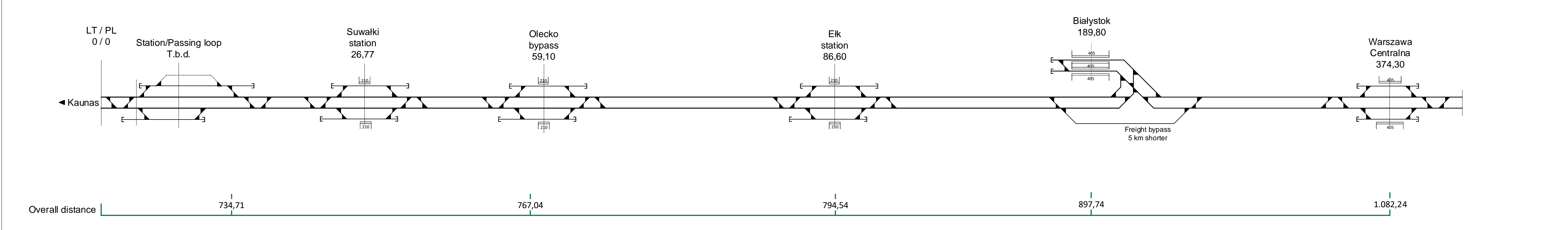

**Kaunas - Vilnius**

